

The Sacred Lost Art
of Eastern Ashiatsu:
Essential Theory and Practice

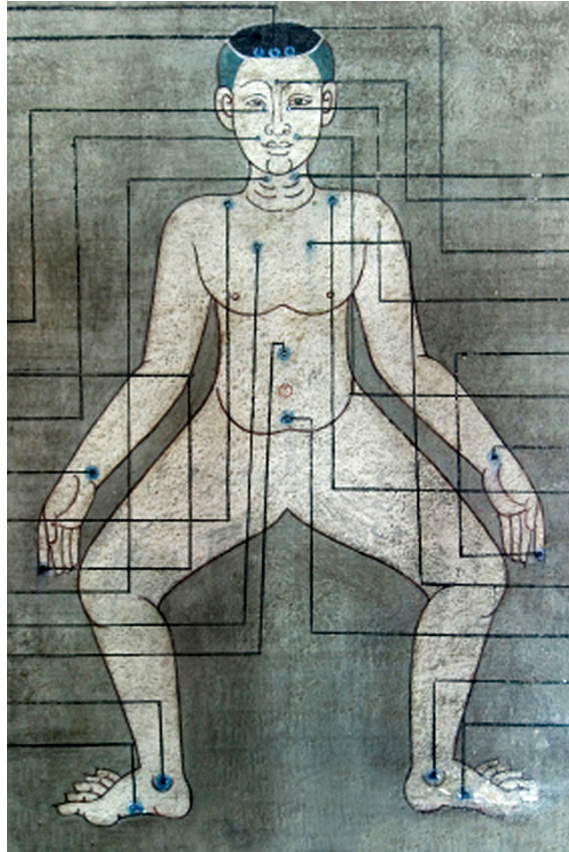

Teragaia.org

By *Rainbowfire*
𠄎 *Lu, Pei Ching*

Editor/Designer
Christy Thorndill
yogachristy.com



Author's Note:

Since 3000 BC Chinese Massage and bodywork has been extensively-studied and practiced throughout Asia. Though the body of Chinese knowledge and data is vast and worth-learning, we can gain greater benefit integrating procedures from various cultures.

As massage practitioners our crafts are extensions of grace. A golden rule we constantly remember is “as we give so too shall we receive.” Embracing healing remedies can enhance our spiritual capacities to receive higher vibrations, thus lifting our ordinary perceptions of pain and separation to that of universal oneness. There are many modalities that can bring us towards this oneness: massage art, acupuncture, transformational breathwork, sound and light-therapy, and vibrational/multidimensional healing modalities such as emotional, ancestral cord-cutting, and discarnate entity release work.

With humanity's awareness being the focal point of true epochal change we can, with a healed and whole self, become the change we wish to see in the world.

Gratitude Love Family

I thank the Masters for their amazing body of grace and knowledge.

*I love and appreciate the support of my creative team,
Christy Thorndill (Yoga Christy), designer of this book, and
Bobbie Bellito of Media Phoenix League, my graphic/web designer.*

*Thanks to all who are opening your hearts to this amazing healing system.
May it be a grace-filled vehicle of transformation of loving service to you and
the many hearts you touch everyday.*

*I thank my beloved teacher, Mukti Michael Buck of the Vedic Conservatory,
for your beautiful wise and inspiring presence in my life. Thank you beloved teachers of Chinese
Medicine and Massage Arts. May I always serve the wisdom of your teaching.*

Thank you Gurumayi.

I love, honor and appreciate the power of truth you have initiated in me.

*I extend my gratitude to our beloved Mother Earth and the Soul of Lady Gaia.
May her boundless love and treasures be discovered again and again through
the pure hearts of her children.*

*Lastly, let me thank you father, mother in heaven.
May your spirits forever guide my sail home.*

Rainbowfire

Lu, Pei Ching

As a master massage healer with over 19 years of continual practice and refinement, she has provided healing for hundreds. *Rainbowfire* PC is a Continuing Education provider and teacher of the Traditional Chinese Medical massage art and healing system. As an activist she pledges to serve her mission, “transforming the planet one being at a time” through her healing presence and music performances.

Since 1997 *Rainbowfire* PC Lu has worked to transform herself on a DNA level, birthing spiritual breakthrough and cellular transformations. At an early age, she discovered her clairvoyance and saw visions that foretold a future she would eventually know and live. Some of these visions have come to pass. Purposeful and strong in leadership, she co-creates divinity as a healer, teacher, sacred activist and singer.

After graduating from The Florida College of Health, earning a Reiki Master Certification from Master Sandy Swanson in 1998, and completing her Traditional Thai Massage training in Chiang Mai, Thailand, she reached out to the world sharing her healing abilities.

In May of 2004, she graduated cum laude from Florida Atlantic University with a Bachelor of Arts in Psychology while continuing her healing massage practice.

Rainbowfire received Shaktipat (kundalini awakening) initiation into the yogic path of meditation with Gurumayi Chidvilasananda, head of the SYDA Foundation in October, 2002. She continues to pledge her devotions as a Bhakti yogini through loving service and spiritual practices.

In November of 2010 *Rainbowfire* was awarded by the Universal Brotherhood Movement with a



Bachelors of Divinity and honored for her ministry: Active “Co-creation of divine love and healing.”

Rainbowfire is a graduate of the Landmark education courses in 2011. In March of 2012 she was invited by Brett Leve, CEO of The Summit group in Eden, Utah, to share her healing talents with the Summit community.

In June 2013, *Rainbowfire* PC became certified by Master Zhi Gang Sha, world-renowned soul healer, and founder of The Institute of Soul Enlightenment, as a Divine Healing Hands Soul healer. In June 2014, Master Sha empowered *Rainbowfire* by gifting her certification as a Tao singer and dancer.

Currently, *Rainbowfire* PC is developing training manuals for Traditional Chinese Medical Bodywork.

Her studies of the healing arts, spirituality, music and feng-shui broaden from guiding teachers like Dr. Carolyn Myss, John Friend of Anusara yoga, Lillian Too, Master Zhi Gang Sha, Bo Lozoff, Anthony Robbins, Jeffery Yuen, Michael Buck of The Vedic Conservatory and many more authentic healers, shamans, teachers and spiritual communities.

Facilitating planetary ascension through on-going seva (selfless service) and hosting community programs since 1999, *Rainbowfire* shares her passion in serving humanity.

CONTENTS

ESSAYS

- 4** BIO: RAINBOWFIRE LU, PEI CHING
- 9** DA BEI ZHOU
- 12** TERA GAIA MISSION
- 14** CHINESE HEALING ARTS: A BRIEF HONORING OF HISTORY AND MEN
- 15** MY TEACHER WEIWEI
- 16** PURPOSE & PRINCIPLES OF ORIENTAL MASSAGE & BODYWORK
- 17** FIVE-ELEMENT THEORY IN OUR HEALING PRACTICE: THE HARA
- 19** THE HARA: A PROCESS FOR LIFE IN THE 4TH DIMENSION
- 21** MEDITATION: YOUR HEALING ROOM AS A SANCTIFIED SPACE, FIVE-ELEMENT THEORY IN MIND AND MOTION
- 24** HUMILITY IS THE DOORWAY TO COMPASSION AND DIVINE SERVICE
- 26** ATTUNING TO HIGHER CONSCIOUSNESS: YOUR BODY A VEHICLE OF POWER AND GRACE
- 27** CHI AND THE PATH OF CHI
- 28** WHAT ARE MERIDIANS AND THEIR FORMATIONS?

ESSENTIALS OF TRADITIONAL CHINESE MEDICINE

PART 1: YIN-YANG

- 31 TAIJI & THE 1ST CORRESPONDENCES
- 32 THE FOUR SEASONS
- 33 THE FOUR ASPECTS OF YIN-YANG RELATIONSHIP
- 35 APPLICATION OF YIN-YANG TO MEDICINE
- 37 YIN-YANG AND THE BODY STRUCTURE
- 38 BASIC YIN-YANG QUALITIES IN THE CLINICAL PRACTICE
- 38 CLINICAL SIGNS ASSOCIATED WITH YIN-YANG
- 39 SUMMARY: RAINBOWFIRE

PART 2: THE FIVE ELEMENTS

- 41 THE FIVE ELEMENTS: INTRODUCTION
- 42 FIVE ELEMENT THEORY
- 44 FIVE ELEMENT CORRESPONDENCES
- 45 FIVE ELEMENT INTERRELATIONSHIPS



**PART 3:
VITAL SUBSTANCES**

- 49** THE VITAL SUBSTANCES: INTRODUCTION
- 50** FUNCTIONS OF ESSENCE (JING)
- 51** THE THREE TREASURES
- 52** QI
- 52** CLASSIFICATION & PRODUCTION OF QI
- 53** BASIC FUNCTIONS OF QI
- 54** PATHOLOGY OF QI
- 55** MINGMEN, YUAN QI AND YUAN-SOURCE POINTS
- 56** AXIS, ROOT AND OUTER WHEEL
- 58** BLOOD
- 61** SHEN
- 63** CONNECTIVE TISSUE (SAN JIAO OR INTERSTITIUM)
- 69** ASHIATSU AS BODYWORK MAGIC

THE SACRED LOST ART OF *EASTERN ASHIATSU*

ASHIATSU TABLE SEQUENCES

- 70 SUPINE: HARA ABDOMINAL ACTIVATING/PACIFYING SEQUENCE
- 76 SUPINE: BAREFOOT ROUTINE ON LEGS
- 80 SUPINE: BENDED KNEE SEQUENCE
- 82 PRONE: BAREFOOT ROUTINE ON LEGS
- 86 PRONE: BACKWALKING ROUTINE
- 93 PRONE: BENDED KNEE SEQUENCE
- 96 PRONE: WHEELBARROW SEQUENCE

REFERENCE MATERIALS

- 101 SAFETY GUIDELINES FOR PRACTITIONER ON BARS
- 102 GUA SHA
- 103 ACU-MAN: YOUR MERIDIAN DRAWINGS
- 106 SELF-CARE: THE COSMIC LAWS OF OUR SPIRIT & THE GRACES
- 107 THE EIGHT TRIGRAMS & THE EXTRAORDINARY VESSELS
- 108 BIG PICTURE
- 109 TERMINOLOGY REFERENCES FOR BAREFOOT MASSAGE
- 110 TERMINOLOGY INDEX
- 111 CHART KEY: ABBREVIATIONS FOR TRADITIONAL CHINESE ENERGY LINES (MERIDIANS) AND POINTS

DA BEI ZHOU (*The Great Compassion Mantra*)

Initial Vows of Great Compassion Dharani Recitation (English Translation)

“If there are monks (Bhikshus), nuns (Bhikshunis), laymen (Upasakas), laywomen (Upasikas), pure youth and maidens who wish to recite and hold (keep reciting) this mantra, they should first arouse their great merciful and compassionate hearts for all living beings, and follow me [Avalokitesvara] in making these vows:

(* The pronunciation of “Namo” is [na:mo:] in international phonetic symbols)

*Namo great compassionate Avalokitesvara,
May I quickly know all Dharmas;*

*Namo great compassionate Avalokitesvara,
May I soon obtain the Wisdom Eye;*

*Namo great compassionate Avalokitesvara,
May I quickly ferry all living beings (to the
shore of liberation);*

*Namo great compassionate Avalokitesvara,
May I soon obtain virtuous skillful means (to
enlighten various living beings);*

*Namo great compassionate Avalokitesvara,
May I quickly board the Prajna Boat;*

*Namo great compassionate Avalokitesvara,
May I soon transcend the ocean of suffering;*

*Namo great compassionate Avalokitesvara,
May I quickly achieve precepts, Samadhi and
the Way;*

*Namo great compassionate Avalokitesvara,
May I soon ascend the mountain of Nirvana;*

*Namo great compassionate Avalokitesvara,
May I quickly dwell in the house of non-
action;*

*Namo great compassionate Avalokitesvara,
May I soon unite with the Dharma-Nature
Body.*

DA BEI ZHOU (*The Great Compassion Mantra*)

Chinese Version

Qian Shou Qian Yan Wu Ai Da Bei Xin To Lo Ni

Qian Shou Qian Yan Wu Ai Da Bei Xin To Lo Ni

Qian Shou Qian Yan Wu Ai Da Bei Xin To Lo Ni

1. Nan Mo He La Da Nu Do La Ye Ye
2. Nan Mo Wo Lie Ye
3. Bo Lo Jie Di So Ben La Ye
4. Pu Ti Sa Duo Po Ye
5. Mo Hu Sa Duo Po Ye
6. Mo Hu Jia Lu Ni Jia Ye
7. An
8. Sa Ben La Fa Yi
9. Su Da Nu Da Xia
10. Nan Mo Xi Jie Li Do Yi Meng Wo Lie Ye
11. Bo Lo Jie Di Shi Fo La Leng To Po
12. Nan Mo Nu La Jin Chi
13. Xi Li Mo Hu Ben Do Sa Mi
14. Sa Po Wo To Dou Shu Peng
15. Wo Shi Yun
16. Sa Po Sa Duo Nan Mo Po Sa Duo Nan Mo Po Qie
17. Mo Fa Te Dou
18. Da Zhi To
19. An Wo Po Lu Xi
20. Lu Jia Di
21. Jia Lo Di
22. Yi Xi Li
23. Mo Hu Pu Ti Sa Duo

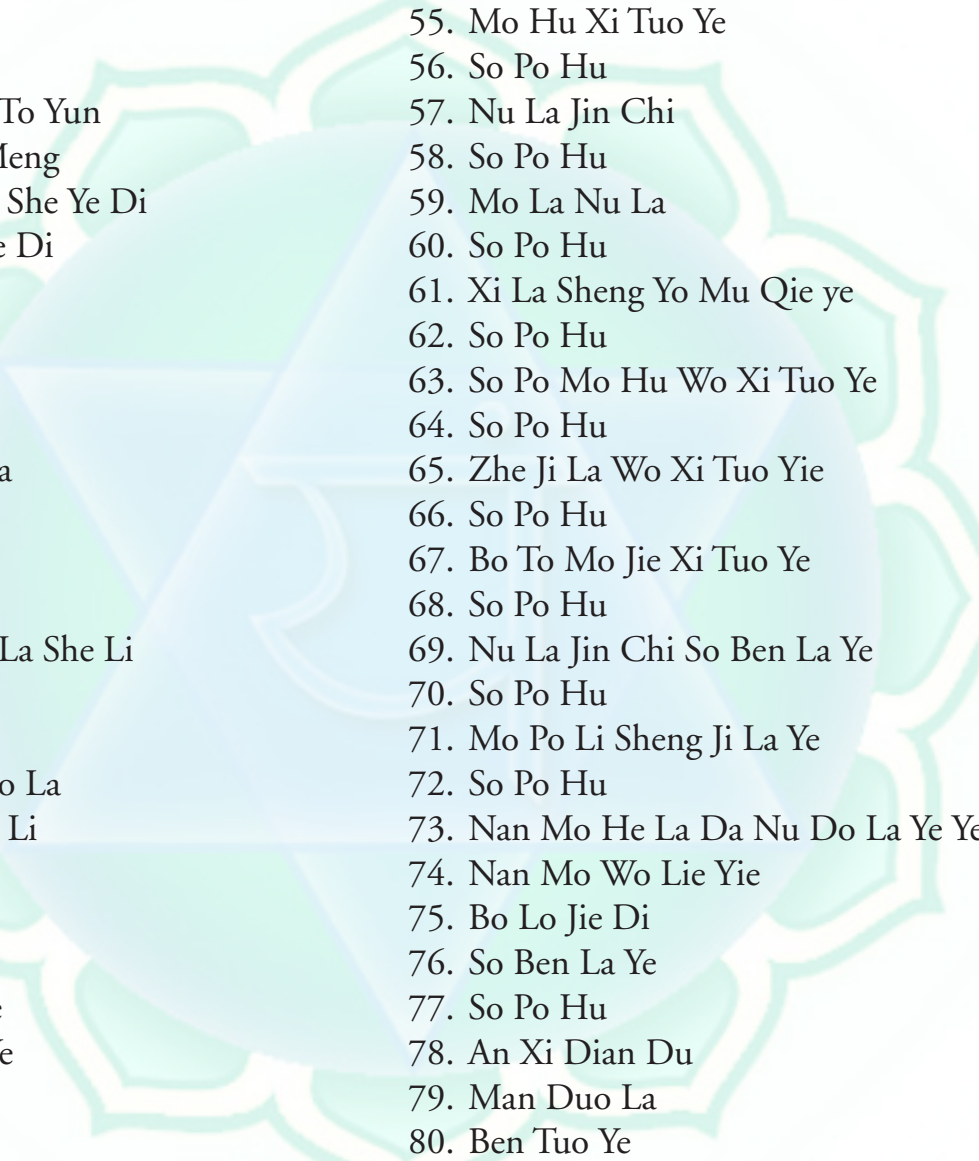
- 
24. Sa Po Sa Po
25. Mo La Mo La
26. Mo Xi Mo Xi Li To Yun
27. Ju Lu Ju Lu Jie Meng
28. Du Lu Du Lu Fa She Ye Di
29. Mo Hu Fa She Ye Di
30. Tuo Lo Tuo Lo
31. Sai Li Ni
32. Shi Fo La Ye
33. Zhe La Zhe La
34. Mo Mo Fa Mo La
35. Mu Di Li
36. Yi Xi Yi Xi
37. Shi Nu Shi Nu
38. Wo La Sheng Fa La She Li
39. Fa Sha Fa sheng
40. Fo La She Ye
41. Hu Lu Hu Lu Mo La
42. Hu Lu Hu Lu Xi Li
43. So La So La
44. Xi Li Xi Li
45. Su Lu Su Lu
46. Pu Ti Ye Pu Ti Ye
47. Pu To Ye Pu To Ye
48. Mi Di Li Ye
49. Nu La Jin Chi
50. Sai Li Se Ni Nu
51. Po Ye Mo Nu
52. So Po Hu
53. Xi Tuo Ye
54. So Po Hu
55. Mo Hu Xi Tuo Ye
56. So Po Hu
57. Nu La Jin Chi
58. So Po Hu
59. Mo La Nu La
60. So Po Hu
61. Xi La Sheng Yo Mu Qie ye
62. So Po Hu
63. So Po Mo Hu Wo Xi Tuo Ye
64. So Po Hu
65. Zhe Ji La Wo Xi Tuo Yie
66. So Po Hu
67. Bo To Mo Jie Xi Tuo Ye
68. So Po Hu
69. Nu La Jin Chi So Ben La Ye
70. So Po Hu
71. Mo Po Li Sheng Ji La Ye
72. So Po Hu
73. Nan Mo He La Da Nu Do La Ye Ye
74. Nan Mo Wo Lie Yie
75. Bo Lo Jie Di
76. So Ben La Ye
77. So Po Hu
78. An Xi Dian Du
79. Man Duo La
80. Ben Tuo Ye
81. So Po Hu
82. Jin Gang sheng Zhuang Yan So Po Hu
83. Sheng Wen Sheng Zhuang Yan So Po Hu
84. Mo Jie Sheng Zhuang Yan So Po Hu
85. An Bo Zhe La Xi Lie Xie So Po Hu

TERA GAIA MISSION

By Rainbowfire

I am a passionate healer! Healing is my life.

Without the principles of preventive health care and the transformations of a pure spiritual revival our world will quickly advance in its devastations. A healing perspective is needed to save us from the source of pain and disharmony that is ultimately our disconnection with our true divine nature.

After leaving my hometown, Queens, New York, at age 19, life seemed like a whole new vista for me. I was free from the usual harassments of a dysfunctional home life and for a while I felt I was safe and happy.

Then after a series of disappointing relationships I sought to the heavens for answers. I had asked God, "Why am I here? For what purpose was I born?" The answer I received changed my life—To love, to love, I am here to love!

This message was more than words could describe. It was a spiritual awakening. I became aware that the world was so much more than what I had been shown. Growing up in the tough streets of NYC made me hard and calloused to my feelings, which were raw and unprocessed. I didn't like myself most of the time. I felt alone and rejected.

Then when God spoke to me and offered a vision of what I could become - what I would become - I leaped for joy at the call to serve humanity and embarked on a seven-year journey of powerful transformations.

This road was not an easy one. I suffered a great deal because I needed to go deep into the abyss of my soul and heal wounds that were physically invisible but spiritually debilitating. Throughout the hardships my visionary sense was always a guide, albeit a strange and enigmatic one.

I had sought to God for the highest and wanted nothing more than to serve the highest. But what did that mean? How was I to know myself if I had never experienced what was out there?

It would have been easy if someone handed me the answers and then I would be done with it right? Wrong! I was to enter the domain of light within and search for the truth in my very own self.

Yes. Yes. Yes. I needed to learn through experience and create my life without fear. This sounded fabulous. I thought it would be easy and whatever tests came my way I would surely pass with flying colors. Boy, was I wrong again. I had personal expectations of how I would do but did not ever expect to lose so much along the way.

What I am saying to you is this: mastering the soul is the only way to the ultimate Trust in life and it is not easy if you are filled with self-limiting concepts. As warriors of light in this modern spiritual day, the simple truths that the masters teach can guarantee our safe arrival. Our only stumbling blocks are the conditions we've hypnotized unto ourselves from dimensions too subtle for our detection.

Sure, we can lose to self-doubt, pain and suffering, but when we can learn from our past, our relationships and regain the power of authentic self-love we acquire mastery over our souls. We become blessed by the light of the warrior and realize the glory of who we really are.

There are many paths worth taking. The quickest and highest path in my own spiritual revival process was that of a wounded healer. This archetype is defined in Sacred Contracts by Dr. Carolyn Myss as such:

“The wounded healer is initiated into the art of healing through some form of personal hardship, anything from an actual physical injury or illness to the loss of all ones earthly possessions. Regardless of the shape of the wound, the challenge inherent within this initiation process is that one is unable to turn to others for help beyond a certain degree of support. Only the initiate can ultimately heal the wounds. If it is an illness or accident it will frequently be one for which there is no conventional cure. The wounded healer archetype emerges in your psyche with the demand that you push yourself to a level of inner effort that becomes more a process of transformation than an attempt to heal an illness. If you have successfully completed the initiation, you inevitably experience exceptional healing, and a path of service seems to be divinely provided shortly after the initiation is complete.”

My path has been true to this description of the wounded healer. Believe me, I was not a bit motivated for personal transformation early in my young adult life. Yet the call to become a channel of divine love and healing power was unmistakable.



Though the wounds have healed, the passion to serve is more vivid and urgent than ever. I feel so many people are on their personal paths of spiritual revival and are a part of a cosmic plan that is greater than the Earth herself. Transforming the planet one being at a time is the mission of the Tera-Gaia Foundation.

No longer obstructed by old fears and self-limiting illusions, I am once again a guardian of our Earth. Our friends in the circle of love and life are many, and more are calling for a reunification with spirit and to be released from pain.

We uplift our planet by changing ourselves (cells.) We change ourselves by healing our souls. The co-creative art of loving service is a science and an invaluable source of learning. The waking up and healing of our wounds is a must for real universal upliftment.

From this vista, let the foundations of trust, humanity, love, beauty and goodwill prevail over the darkly-driven ways of our fundamentally-challenged and confused society.

CHINESE HEALING ARTS: A BRIEF HONORING OF HISTORY AND MEN

By *Rainbowfire*

It was in ancient China where the first forms of healing arts began. As medical thinking and practices in China today are inextricably woven within its religion, philosophy and arts, we know very little of its mythical beginnings.

The earliest and one of the epic classics dating before 2500 BCE is a medical text called The Internal Classics of the Yellow Emperor. It was accredited to be written by a legendary emperor named Huang Di who lived over 100 years and reigned peacefully during the Han dynasty (206 B.C.E.- 25 C.E.) During this period Chinese medicine flourished and the Silk Road was mapped and irrigated. The book is oft-quoted by scholars and medicine texts as an important area of study.

This classic is comprised of discussions between Huang di and his chief minister Chi' Po in the philosophies, medical mandates and practices of energy relations. It emphasizes the Great harmony achievable by man's paths of harmony within oneself, family, society, nature and eventually, all of nature including the supernal aspects of the cosmos.

It is arguably so that massage is the first form of medicine ever practiced in ancient China. The village healers and shamans used rubbing and scraping to heal pain in the body and developed a map of points which were reliably effective. Later on, instruments of stone and then finer needles were introduced.

Massage is considered the oldest of the four branches of traditional Chinese Medicine; massage, acupuncture, herbs and qi gong. All forms of medical bodywork today have their roots in the mother language of ancient Chinese origins, ie. meridians and chi.

I'd like to pay a few words of respect and humbly thank the honorary works of a few literal and historical figures whose integral contributions to the healing arts today has been a healing balm to the civilizations of their times. Taoism, Buddhism, martial arts, feng-shui (art of placement, sacred geometry), I Ching (Book of Changes), the annals of medical logs, studies of warfare and divination practices have evolved from the great minds of so many wise and beautiful spirits such as Fu Hsi, Huang di, beloved masters of the temple healers, sages Lao Tsu and Hsi Neng, legendary herbalist Li Shi Zeng, socio-political leader Confucius, the beautiful goddess (Kuan Yin), shamans of the Er-Mei mountains and Tibet, and of course our beloved ministers of ancient China. Truly their spirits I invoke to reveal the light of healing in me and the world in which I live.

Their contributions to Ying-Wei, the systems of healthy living and maintenance of body/mind, home, village and government has fundamentally become a part of this amazing and beautiful life and continues to enrich my existence daily. Thank you to the generations of Soul Masters before me and beyond.

MY TEACHER WEIWEI

By *Rainbowfire*

Barefoot Massage training became a passion in the summer of 2003. I received a treatment from a woman healer (another beloved dragon spirit born 1952), and was jaw-dropped amazed at the depth, stealth and sheer brilliance of her plantar claws.

They were as sensitive and tactile as the hands, and even more powerful than the palms due to the power differential of the lower extremities.

The day I encountered Weiwei felt like a huge blessing. Her healing hands actual glowed the color green, the vibration of renewal and regeneration.

Weiwei has the physicality of a martial artist with a mid-torso as wide as her self-illuminating smile. She is a wise soul and a beautiful healing spirit.

From then on we became fast friends periodically exchanging since 2003. Today after 50 treatments or so and a two-week visit in Delray Beach, Florida where I got to observe her flying movements on bars across the body on 9 patients, I have absorbed her transmissions and have acquired the jing (or vital essence) of Weiwei's powers.

Aside from the technique from Weiwei's treatments, I was able to discover the true spirit of Asian bodywork, its tao, its compassion and grace-filled efforts.

The generational contributions of skill and creativity channeled through beings such as Weiwei humbles me to such a pulp that I remember, "Honor the ancestors, honor the divine."

Weiwei is a Soul sister and I feel destined to have met her. Let me offer you a brief history of her background:

Weiwei is a mother to a son living in Hong-Kong, China and grandmother to a beautiful granddaughter.

Having immigrated to NYC in 2002, she resides in Flushing, New York City, practicing her massage art while supporting her family back home.

A natural-born leader and healer, Weiwei was famed by the growing notoriety of her talent within the Cantonese community. She told me once that a contest was held in Hong-Kong early in the 1980's and out of 300 competing members she won first place. A strong achievement indeed!

I believe there is no one like her on this planet. I recognize her as a master amongst the thousands who do barefoot massage.

I have tremendous gratitude for my teachers and commit to healing more and more people with every blessing received from the ancestral lineage of Oriental Massage and Bodywork.



PURPOSE & PRINCIPLES OF ORIENTAL MASSAGE & BODYWORK

By Rainbowfire

All massage is healing. Oriental massage therapy is specific in its actions in that its foundation of Chinese medical theory and Vedic-Thai healing systems makes it a form of medical bodywork.

A variety of techniques you will learn have the following effects on the body:

- Dredges, Clears and Expels unwanted pathogenic factors
- Invigorates jing or vitality
- Aligns tendino-musculatures of meridian channels
- Balance neuro-chemical/glandular systems
- Resets nervous system by soothing the centre and calming shen
- Releases hydraulic pressure from the four limbs and trunk of the body
- Heals deep tissue wounds
- Stimulates circulatory/lymphatic systems
- Invigorates Qi and blood
- Breaks deep tissue adhesions
- Adjust and aligns the myofacial network of the neck, head, spine and lower limbs
- Affecting cellular transformation
- Revitalizes the major vital functions of the digestive, elimination, circulatory/lymphatic, respiratory, nervous/electrical, musculoskeletal systems
- Treatment of postural and emotional holding patterns
- Lubricates and facilitates the movement of joints
- Beautifies the spirit through cellular regeneration
- Restores, harmonizes, and balances Wei Qi, Ying Qi, Yin and Yang

Tui-na, Vedic-Thai postures and barefoot massage techniques aim to achieve this through:

- The rationale and principles of Chinese medicine and Vedic-Thai systems of healing
- The therapeutic effectiveness of the techniques' application
- The method of application--the practitioner's intention and ability to direct their awareness and Qi flow

FIVE ELEMENT THEORIES IN OUR HEALING PRACTICE: THE HARA

By *Rainbowfire*

In Classical Five-Element theory we acknowledge the qualities each element characterizes throughout the functional dynamics of observable phenomena. These laws were codified by the Chinese thousands of years ago. These laws are present in Chinese healing arts such as feng-shui and meridian theory, in great detail of its phases and interrelatedness. Use of its knowledge in our massage healing practice can provide us a standard of reference that is unlike an ordinary massage.

The movements of primordial energies as it relates to the characters of each element helps us connect to cosmic awareness of self to self, soul to soul, being to being and establish realizations of ourselves as microcosmic units of the macrocosmic universe.

Along with the categories given in the chart following, each element is associated with a particular yin/yang aspect of emotion and virtue:

- Water (fear/wisdom)
- Wood (anger/benevolence)
- Fire (joy/propriety)
- Earth (sympathy/integrity)
- Metal (grief/righteousness)

In the regenerative/productive cycle known as Sheng, the virtues corresponding to each element are expressed effortlessly through the quality of qi that is natural in the inherent procurement of balance of their phases within the body. Within a healing massage exchange, the qi or prana of each element progressively travels about the body and rhythmic harmonies of multi-sensory vibrations physical and non-physical are transferred from one vessel to another.

These qualities are natural harbors of true healing vitality and creative life flow. A human being that is at one with the inherent virtues of each element is one who is at one with the Dao, the primordial influence of the cosmos. Inversely, when there is disharmony and afflictive emotions arise, we need to be present to the virtues: this is when careful attention to the quality of our inner state matters.

This inner state is very deep, cellular even, and often ignored in ordinary states of consciousness. Where the massage and healing practice needs to deepen is at this level of our being. It is at this deep, cellular and creative level where all healing takes place.

In the navel are the five emotions and its afflictive states housed:

- benevolence and anger lives in the liver
- joy/propriety and depression/anxiety lives in the heart
- worry and sympathy/integrity lives in the spleen
- righteousness and grief lives in the lungs
- fear and wisdom stores itself at the kidney basin

As our organs and jing (life-force) reside in the navel, its qi flows, disperses, travels and fuels the living systems integrated within our anatomy.

Chinese and Vedic medicine acknowledge that all healing manifests in the navel. In traditional oriental massage systems our orientation of 'sensing' this integrated field of the human energy anatomy is through our navel center the Japanese call hara.

“The pulsation (literally, moving Qi) between the kidneys located below the navel is the life of the person. It is the root of the twelve meridians. It is therefore called the source.”
- from the Classic of Difficulties

Five Element Life Qualities:

Wood - beginning, birth and newness; life emerging from the ground

Fire - expansion, thriving, flourishing; moving away from the initial growth of the dark earth to growth and creativity

Earth - nurturing, sustaining, ripening; it is the maturation process whereby the balance of virtues attains the integrity of its acquired nature; its embracing qualities reflect the eternal oneness of heaven; it is the mother of the human heart whereby the fires of life dance upon; in its contraction state earth is seen in metal

Metal - inclusions of the earth element; rarified treasures such as gold and platinum are classified here; the virtues of righteousness centers (earth) our every movement; its organ associations are lung (yin) and large intestine (yang); the manifestation of harmony between mind-body-spirit (shen) acquires righteousness as its storehouse of primordial forces moves about the expressions of life and reaps harvest of the vitalities of wood, fire and earth

Water - emerging from the metal the cycle ends in one phase while the primordial *Dao* transits unto another; the hidden seeds of new beginnings lying still beneath the dark earth as the motions of water imperceptibly stir with life

FIVE ELEMENT CORRESPONDENCES					
ELEMENT	WOOD	FIRE	EARTH	METAL	WATER
SPIRIT	HUN (ETHEREAL SOUL)	SHEN (MIND)	YI (INTELLECT)	PO (CORPOREAL SOUL)	ZHI (WILL POWER)
YIN ORGAN	LV Liver	HT Heart	SP Spleen	LU Lung	KD Kidney
YANG ORGAN	GB Gallbladder	SI Small Intestine	ST Stomach	LI Large Intestine	UB or BL Urinary bladder
BODY TISSUE	Tendons/Nails	Blood Vessels	Muscles	Skin	Bones/Joints
BODY FLUIDS	Tears	Sweat	Saliva	Mucus	Urine
SENSE	Eyes/Sight	Tongue/Taste	Mouth/Lips/Speech	Nose/Smell	Ears/Hearing
UNBALANCED EMOTION	Anger	Depression/ Anxiety/ Excitability	Worry	Grief/Sadness	Fear
BALANCED EMOTION	Benevolence/Patience	Joy	Love/Compassion	Courage	Calmness
FINGER	Index	Middle	Thumb	Ring	Little
TASTE	Sour	Bitter	Sweet	Pungent	Salty
COLOR	Green	Red	Yellow	White	Blue
WEATHER	Windy	Hot	Damp	Dry	Cold
SEASON	Spring	Summer	Change of Season	Autumn	Winter
DIRECTION	East	South	Central	West	North
PHASE	New Yang	Full Yang	Yin/Yang Balance	New Yin	Full Yin
ENERGY	Generative	Expansive	Stabilizing	Contracting	Conserving

“THE HARA”

A Process for Life in the 4th Dimension

By *Rainbowfire*

Of all the aspects about the Hara I have learned, the most insightful for me is that the source of the Hara's life force, underlies, while it transcends, the most physical dimension of our human experience.

“Di” means two and “mension” means to measure. The measurements between two points of reference that become manifold when we add depth, width and height. That would be three dimensional.

When we apply this to the biological idea of the Hara, we access a deeper dimension of life force call the universal quantum field. I learned about this concept through studying the works of Barbara Ann Brennen, author of ‘Hands of Light’ and ‘Light Emerging’. You can find her descriptions about the Hara and the three energy centers call Dan Tians in the ‘Light Emerging’ book. In it she writes that the Hara lives in the fourth dimension. It is a laser-like line connecting the three Dan Tians or energetic anatomies with the life-force of prana that's flowing through them.

The Hara is also home to the organs. In Chinese Medicine we categorize them using the five-element system. While this system is a universal concept that can be applied to the cosmology of the universe and nature, when applied to the organs it is then categorized into the multi-sensory perceptions of each organ.

How can we develop our powers of perceptions towards the most pleasurable realms using our life-force? As artists we lift the veils from ordinary thinking towards heavenly spirits by the system of creating, balancing and harmonizing our life-force via the wisdom of the Hara.

Vedic medicine refers to the area as Nabhar, which means ‘the bright shiny stone that solves and remedies.’ In Greek the belly is Om phallus and in Latin it is umbilicus.

Think about the fragrant earth as we rise in the morning. The movements of mammals awakening to the fires of the first light of day. What do they do? Are they thinking about what they did yesterday? No. They are lifting and opening their mouths to the nourishment of their environment. Breathing in air and foraging water, food and warmth. They connect to life using their organic senses.

How do we as humans anchor the wisdom of being? We let go of our cerebral conditioning and enter the garden of life-force via the multi-sensory perceptions of the Hara.

“The pulsation (literally, moving Qi) between the kidneys located below the navel is the life of the person. It is the root of the twelve meridians. It is therefore called the source.” from *The Classic of Difficulties*

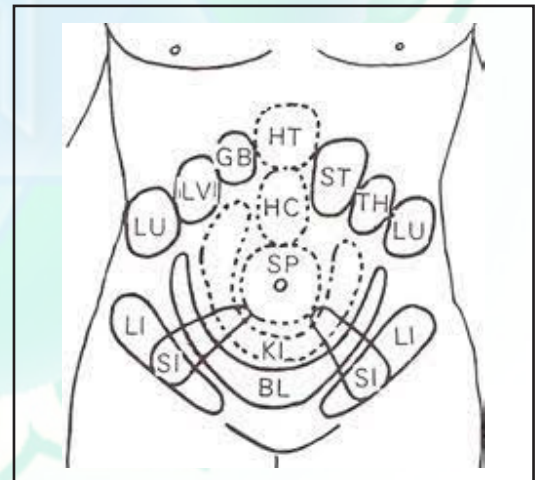

This Haric field of life force resonates to the fourth dimension, to the inseparable matrix of the process of the spirit of physical form living throughout time and space. The fourth dimension as a field is not linear. It is the process of the generation of things as well as the process of Time.

The experience of this spiritual dimension has been called the astral plane. Astral means starry. In the past people thought that when they die, they go to the stars.

That is how the name astral came to being. It has been referred to as having lower, middle and higher planes. It's also considered the place where all things not of the earth plane goes to like ghosts and bad dreams. This is not totally true.

As living DNA, the generating of life-force is a process that replicates itself through the energetic matrices of the fourth dimension. It's like the spider web weaving and projecting itself over and over again. With the DNA as the generating seed, it undergoes the geometry of transformation via replication of its genetic blueprint from the sequencing of cellular multiplication. Like the chromosome it divides, replicating itself and creating new cells. This process is not only happening in humans but in all the kingdoms. This is the materialization of life's processes.

Isn't evolution the division and re-structurization of itself? Do we not see the multiplication of life everywhere across the planet? From seed, to plant, to fruit, to vegetables. The seas, land, forms and currents. The body, spirit and soul forming and re-forming to fulfill itself. Stars, water, planets and its ether evolving and expanding for the purpose of knowing itself. Life is forming constantly, a process by which the eternal mantle of Time is a watch. How many children are born every day? How many cells are dying right now? Time revolves around a constant evolving process of things as life.

Every six months to one year each cell of our body transforms; it becomes a new body. Why not allow our spirits to grow to become a new person? Where does the process begin and our consciousness start?

The information has been pervasive. We are surrounded by it. Are we the same? Are we the same information replicated through the shaping of time? Or are our patterns the same? Who are we living on this planet? Do we actually die or are we replicated again and again via the process of things? We all end up decaying. Becoming a new form through transformation learning new experiences, expanding our energies as perspectives of ourselves.

What is the feeling when we die? Imagine the exhale of the soul like a butterfly outgrowing its chrysalis or

distributing a new form of itself.

Everything that was once compressed will eventually come out, expanding and reshaping itself through a process, the reality of itself projecting into the fourth dimension.

What we are inside as we project as an expanded version of that will be a manifestation that's in proportion to its vibration. If we expand from a high vibration what we see and experience as ourselves in the fourth dimension will be a high vibrational manifestation. If we are doing the same from a low vibration, we will manifest those experiences.

If I expand in Christ, I will become the Christ form. If I expand as Buddha, I will experience the Buddha. And on and on. Our focus as we are within becomes that in the fourth dimension.

If there are misalignments in the structurization of the nodes within the dimensions of the human energy field this constant spiritual process can get distorted from its original blueprint. Like the nodes within a three-dimensional cube with some nodes misaligning, there are problems that can occur. The energy can't run properly.

An example would be if our chakras, which are energetic nodes for the human beings processing of life-force, become misaligned and have holes. Then low vibrational entities, demon consciousness and various other forms of spirit attachments from dark energy portals within the fourth dimension can attach and feed off that human. Thus, diseases of the hara ensue with the misalignments and the negative entities being the cause of disease.

This is a real etiology for our planet today. It was taught to me that 90% of people on our planet suffers from dark entity and spirit attachments. Knowing this can we really heal through modern medicine alone?

No, we reshape ourselves through the waking up and healing of our wounds. We must take the health of our bodies and minds from the mis-coordinates of today's unwise thinking and turn our attention towards the unification of the trinity on behalf of our soul-spirit-body or jing-qi-shen. It is a must for real universal upliftment. Oneness is who we are as life!

Meditation: Your Healing Room as a Sanctified Space, Five-Element Theory in Mind and Motion

By Rainbowfire

The difference between a massage and a healing is consciousness. Practicing authenticity and balancing the inner being empowers your spirit or shen to acquire mastery of true self-expression, of harmony with your original nature.

The sanctity of nature is unsurpassed in her simplicity and beauty. Let's invite the wisdom of the five elements into the healing room.

The element **Wood** is represented through sight. Visually one can sense the qualities of your professionalism, artistry, and who you are from the display of your healing room.

In Feng-Shui the color green relates to healing, regeneration, rebirth and newness. The wood element can also be represented in plants though they should be healthy and vital.

First impressions distinctly set the tone of the exchange. Are you expressing your intent at first sight through your vitality and presence? How does your field or aura appear to others? Can they feel through their eyes how present you are with them?

Fire represents expansion, growth and the moving away from earth in a thriving force. The fire element can be activated using candles, lights and music. Fire in the healing room supports the vision of spiritual intention.

As a meditative tool it opens the third eye as in Tratak meditation* and frees the perception of dross and darkness. You have seen how lighted candles in a darkly lit room improve the ambiance dramatically or even how a crowd of people light up just by the sound of music.

Can you receive criticism well or offer instruction with clarity of intention? How does your voice appear to your client? Can you exercise self-control over the motions of your belly? Is the intensity of your strength in sync with the client's needs?

Fire is a primal force that often goes neglected or is used in excess. With pure conscious awareness fire is channeled with an arrow and the control factor for this lives in the navel. As artists we need to constantly adjust our procedures to harmonize with others, hopefully doing so in an inspiring and enlivening way.

As your vehicle becomes purer and stronger the realization of fire in your center awakens you to newer discoveries. The masters of Asia so often use fire, incense sticks and candles in ceremonies to awaken the fires of the soul/spirit.

It is necessary to perform some form of puja or spiritual ceremony for the invocation of grace in ones healing room. Even as the sun performs its daily ritual by rising and enlightening this entire planet from a slumbering night sky so too do fires of spiritual attunement and ceremony offer freedom from the inert, unconscious tendencies of the mind and body.

Consciousness as it is represented by the fire element is very potent. As the conscious flame of your healing magnetism intensifies you expand and move away from the grounds of earth and transporting yourself to the fiery dimensions of light and sound. Perceptions of the spirit replace ordinary thinking.

The revealing purity of a sanctified space offers both the giver and receiver rejuvenation and complete tranquility.

***Tratak-meditation on light.** A soft gazing at a candle flame, traditionally a burning ghee lamp, without blinking the eyes, until the eyes tear. Then closing the eyes and directing the attention to the brow center, allowing the afterimage to glow while staring into it.

Earth in a healing room is activated by crystals, stones or pictures of mountains. It represents maturation, ripening and nurturing.

Our transitions to earth now speak in the deliverance of the massage/healing exchange. The maturation process deepens as both the giver and receiver transmit encouraging messages and nurtures the embrace. The client is in the arms of a communication very much so like a parent and child.

For the therapist the message of healing is being communicated through the hands in a massage or through the mind in a counseling session. I often do both and am reminded how the parent-child communication powerfully affects the actualization of the healing intent.

Here are some questions to consider from the perspective of our mature earth-like qualities: Can I set boundaries within a healing session so as to communicate a message while maintaining integrity of professionalism with the client? How do we properly address the mind during a session?



Can the draping procedure be a way to define our boundaries? How long can I give a session without exhausting my own supply of vitality? Can I honor the integrity of my self and others in the session? How does that translate in the language of touch?

Another artistic concept to utilize during a massage is the parent-child hand communication. Mukti says this about it: *“Parent-Child Hand Communication is the reciprocating response being exchanged between the two hands while administering a massage procedure. To achieve a first-class experience in a massage session, the PIC Communication must be present. This PIC Communication functioning harmoniously amid the two hands is living consciousness and provides the receiver with pleasant uniformity and steadiness during a treatment.”*

Metal during a massage is seen in several ways. Through aromas and at the spirit levels of perception, for lungs govern the corporeal soul.

Spiritual aromas of light and love exude grace-filled energies one detects through the element metal. This is why as practitioners we practice puja, worship, attunement exercises and meditation.

Have you ever been in the presence of a powerful spiritual being? I have, and on many occasions the spirit light of that exchange was subtle yet so powerful that their impact affected the very way I perceived reality.

Metal accounts for the responsiveness of the body and its associated righteous feelings. You sense goodness and perceive consciousness from the soul qualities inherited by the metal phase.

As in the sense of smelling, aromatherapy oils can elicit emotional responses, activating subconscious memories present in the souls' psyche.

In metal, we harvest what has been collected from the birth and growth of wood, the expansion of fire and the ripening of earth. As these elemental dynamics richly gather and harmonize, creation itself inspires the being towards serenity and bliss.

Through the deepening of breath awareness and vitality the virtues of righteousness is absorbed into the cells via the strength of metal.



Water emerges from metal as the natural cycle of renewal continues in its yin phase. In the massage treatment, the element water expresses itself in sound and hearing. Are you aware of how sound penetrates the ears and affects the mind?

Water rules the kidney/bladder that filters the raw forces of fluids in the body. How is the massage affecting the chemical, glandular and mechanical balance in the body?

What is the recipient's inner state as the session progresses? At completion, see the element of water transformed through the five phases and visualize the stillness of a clear lake.

In the endings are sown seeds of new beginnings.

Rest well knowing you have mastered the grace of incorporating five-elemental meditation. *Namaste...*

HUMILITY IS THE PATHWAY TO COMPASSION AND DIVINE SERVICE

By *Rainbowfire*

As a Bhakti Yogini (on the selfless path of love), humility teaches me fortitude and depth of compassion.

The full spectrum wavelength (darkness and light) of the human/spiritual condition is life itself expressed in yin/yang forms. We are a species capable of direct god communion. How amazing would it be if everyone on earth expresses that on a day-to-day basis?

This is the answer to the victim consciousness prevalent on our planet today: To know and honor oneself and others as direct expressions of god-consciousness. To attain this knowledge a spiritual perspective and great humility is needed.

My beloved sage and master Gurumayi Chidvilasanada, head of the Siddha Yoga Foundation, teaches about the Self, the god-like being we are. This Self is perfect and whole, already at one with creation, content and self-sufficient.

Conventional modes of operation in our modern world easily entrenches us in a state the yogis call doer-ship. When we are under the spell of the doer we become Self-forgetful.

This Self-forgetfulness sounds like this, “Wow how many more of those will I be able to have in the future, I want more of that in my life?” or “I have no patience for this?” or “how do I make this situation stop?” This type of conversation is always about some thing or some event happening outside our selves.

The doer thinks it has a say over what happens and gets mad when unexpected things happen. This doer has a huge field of self-made aggrandizements that also says I have this and this and these are my accomplishments. The doer wants to make things happen for its own sake because it relishes the energy certain of action. The doer’s behavior is affected by personal agendas and has many layers of boundaries of protection and defense.

In the healing room you easily see the doer in the massage therapist. For example, this therapist is easily scattered and forgetful of the truth of what the work is really about, a commitment to the friendliness of being and an offering of grace.

This doer is under the agreement of expectation and believes she is doing a great job and should get rewarded. This therapist has not contemplated the value of his or her heart in the reality of oneness. The action says, “as sure as the experience goes I am receiving what I expect.” Remember the golden rule of healing, “As you give so too shall you receive.”

The Truth is, we are not doing any of it. We simply make our selves available as friends of life and allow experiences to unfold. We can relate to life just like this in everything we do.

We have been conditioned to believe we should get adequate compensation in a world made of a money system that corrupts the human capacity to love. Even in the industry of healing, we

as professionals lose sight of the divine gift of unconditional love and self-love.

Our economic village gets entrained with the agreements of pleasing others and having a motto that says, “The customer is always right” or “Treat the customer like gold.” Not to say that it’s good or bad. It simply is the vibration of economic strategy.

Yet I see that those who really want an authentically creative, non-tempered experience of oneness require a humbler, quieter approach.

The realization of oneness implies that all our actions, thoughts and choices influence one another and our planet.

How do we allow the divine into our lives for a better tomorrow? Unconditional selfless service and compassion is a path the masters speak about again and again. Master Sha, a golden healer of the new times says, “the purpose of life is to serve...the message of universal service is: I serve humanity and all universes unconditionally; you serve humanity and all universes unconditionally; together we serve humanity and all souls in all universes unconditionally.”

To have genuine humility, see from the heart and truly express authentic love for what you feel, knowing that true Self-expression is a genuine gift of universal service.

How many of us overlook or supercede this subtle field call selflessness?

The doer wants it all: money, credit, looking-good and approval. It goes to all sorts of lengths to figure out what to say or do.

This type of Self-forgetfulness leads to more lack and humiliation. Being humiliated is often times a self-inflicted act of horror. Yet in many instances the sting of it helps us look more deeply at the wounded one. Chances are your stories about the humiliation come right from the

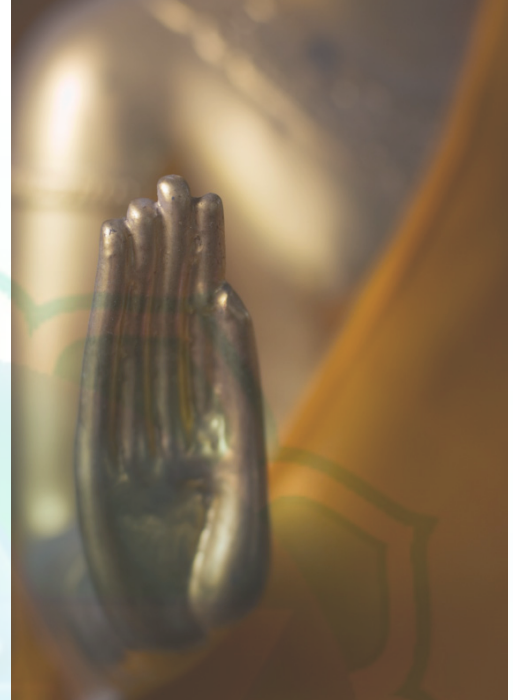

confines of the doer. Humiliation is the flip side to humility, the letting go of self.

Your golden hands release suffering from the world. What an amazing gift and opportunity to serve you have. You are a universal servant of the divine.

As an initiate, do yourself the honor of being that precious extension of grace, with more clarity about your heart’s commitments. We are not born for a job and to make money but to be as we are. We channel our powers into the physical world from a heart that is filled with authentic self-expression.

When we can really just ‘be’ without expectations, wholeheartedly serve others and allow the humility of love to unfold, great miracles happen effortlessly. Take this message to heart and let go of the need to be doing this and that, just flow with an open unfettered heart, be happy and pray before, during and after a session. You’ll be surprised at how amazing the experience will be.

With great love, I pray we become one channel of light in a Mandala of prayer for healing, love and compassion.

ATTUNING TO HIGHER CONSCIOUSNESS: Your Body a Vehicle of Power and Grace

By *Rainbowfire*

Much like the Earth, our bodies are a natural phenomena of the five elements moving from phase to phase.

Inviting the primordial *Dao* unto our awareness means acknowledging the Soul. From here the states of being shifts from ordinary consciousness to extraordinary levels of natural divine perception.

The human anatomy of the bio-magnetic-electrical energy field often called 'aura' is mentioned throughout Vedic, Oriental and contemporary literatures of healing. Let's use Vedic terminologies to further explore our understanding and listen to the words of Mukti, my teacher.

"According to Ayurveda, at any moment, the spirit-soul is represented by 5-bodies, each body encapsulated within the previous more original and radiant body. These bodies are referred to as Koshas in Ayurvedic medicine.

Mostly however, the delights and dramas of the physical and mental koshas have trapped our awareness, relentlessly prohibiting the experience and nurturing of the other spiritual dimensions. We want and need the influx of the other koshas in order to have self-revelation.

The physical kosha is represented by the mysteriously-alluring intervention of our 5 senses (sight, sound, touch, smell, taste.) The mind, being the master juggler of these 5 energies, provides orientation and relativity for the soul.

Each of the koshas are connected to the proceeding koshas by an interfacing pranic occurrence such as a wheel (chakra) or a sphere (marma). Sacred channels (nadis), described as careening rivers of rainbow light, are also constituents of this anatomy and also function on all 5 koshas.

One of the primary objectives of Nuad Borarn, Vedic Thai-Yoga Massage, is to detect obstructions and interferences within the interfacing channels and vortices so as to liberate the region and allow consciousness to flow and radiate freely.

When emancipated consciousness flows and radiates, attuning itself to primordial spirit, then we are experiencing the information and life of the other koshas. We are experiencing our self truly and purely, a most desirable satisfaction that subsequently inspires us to welcome personal evolution, growth and healing."

Our bodies radiate life force. Attuning it to receive higher consciousness brings balance and integrity at the cellular level, thus increasing pranic life-flow throughout the meridians.

As we examine the energy anatomy of the incredible harmony of the body we cannot help but step into the study of the human aura and consciousness. There is an ever-expansive field of light that is imperceptible to the ordinary senses. Our only way into this domain of light is through the aid of spiritual grace, power and wisdom.

As we move from the physical to the spiritual we align to our higher self and expand our energies exponentially. This is a peak experience all beings are eventually seeking for, especially in a healing exchange. Upon the mountain of lush natural scenery we become attuned to the elements of the body, soul and mind reveling within Oneness and bliss.

CHI AND THE PATH OF CHI

By *Rainbowfire*

‘Path of Chi’

What is ‘Chi’?

Chi is form as well as function: the substance that moves, and motivates all life’s functional and physical manifestations.

It is known by many names across cultures. Chinese call it ‘chi’, Japanese ‘ki’, Tibetans ‘lung’, and in Sanskrit it is ‘prana’. In the west, there is no name for it, though it can be considered like the electro-magnetism of the body. I rather enjoy seeing it as that since it is true that in every living cell there are negative and positive charges.

Chi disperses and condenses into many forms, alternating in cycles coupling dynamics of yin/ yang. Chi gives form to these variations, yet is not confined by them and of itself is recyclable. It is in every vital thing we know and see -- from the human body to the living earth -- including plants, minerals, elements and animals. Chi is in all movement -- from the rotations of the stars and planets to the cycles of seasons and space.

So chi is form as well as function. Chi is also movement. The movement about which we will be learning is called the ‘Path of Chi’.

Excerpts from the book *Gua Sha* by Arya Nielsen, published by Churchill Livingston:

- The concentration of chi emanating throughout the trunk and head
- it flows laterally from the vertical channels of the trunk and head
- this path of chi indicates a direct relationship between the brain and face
- the path of chi in the chest connects the upper arm, chest, neck and upper back
- The path of chi in the abdomen relates to the lumbar-sacral region, lower abdomen and the lower limbs
- The path of chi describes the 3 jiaos:
 1. Upper (head, neck, upper chest, arms, head and lung C1-T5)
 2. Middle (Stomach, Spleen, Liver, Gallbladder, trunk T5-L1)
 3. Lower (Kidney, Bladder, reproductive regions and systems, lower extremities)
- The path of chi interconnects the inner-outer body link and accounts for the ability of surface techniques to reach into the organs
- this path also supports the reflexive responses whereby disease on one part of the path can be treated by affecting chi elsewhere along the same segment of the pathway

WHAT ARE MERIDIANS AND THEIR FORMATIONS?

By *Rainbowfire*

The theory of meridians and acupoints are essential parts demonstrating organic wholeness in Traditional Chinese Medicine.

Meridians refer to the routes that transport qi and blood, regulate yin and yang, connect the zang-fu organs and associate the external with the internal, as well as the upper and the lower. It is likened to the network of streams and rivers covering the earth's surface distributing essence to the geological terrains.

Meridians not only connect all the parts of the body but also coordinate their functions. By regulating their own conditions of blood and qi, the meridians influence the states of viscera, regulate activities between the zang and fu organs, the viscera or pores, tendons, bones and muscles, five sensory organs, nine orifices as well as the four limbs and the skeleton. Meridians coordinate the various activities of these different body parts, thus forming a network capable of intercommunication, relaying information, and regulating vital functions of organic wholeness.

The formation of meridians consists of channels, or routes, and collaterals. Channels refer to the longitudinal trunk parts of the meridian systems, while collaterals are the branches of the system.

There are 12 regular meridians, 12 tendinomusculature routes where the meridians pass and interface along the body parts, 12 cutaneous zones, 8 extraordinary vessels and 15 major collaterals and superficial and tertiary collaterals.

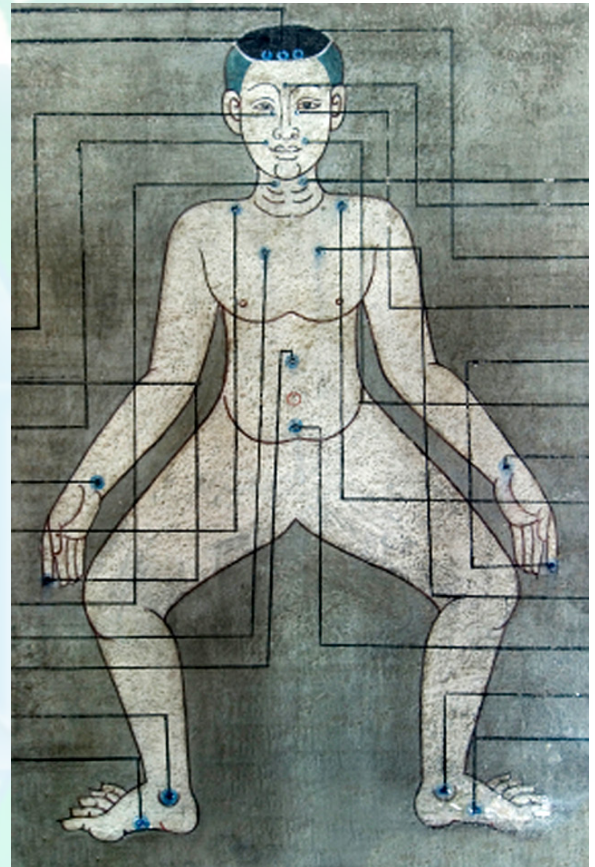

12 regular meridians

1. lung meridian of the hand-*taiyin*
2. pericardium meridian of the hand-*jueyin*
3. heart meridian of the hand-*shaoyin*
4. large intestine meridian of the hand-*yangmin*
5. triple warmer meridian of the hand-*shaoyin*
6. small intestine of the hand-*taiyang*
7. spleen meridian of the foot-*taiyin*
8. liver meridian of the foot-*jueyin*
9. kidney meridian of the foot-*shaoyin*
10. stomach meridian of the foot-*yangming*
11. gallbladder meridian of the foot-*shaoyang*
12. bladder meridian of the foot-*taiyang*

Tendinomusculatures of the 12 meridians

Segments through which meridians pass in their distribution over the deep and superficial areas of the body. Mainly functions to link the four limbs of the body for joint and movement control.

Collaterals

15 major, one for each of the 12 meridians plus *du* and *ren* and a major collateral of the spleen. Collaterals are the branches of the meridian system and are distributed along the superficial tissues of the body.

Together the channels or routes of the meridians' trunk parts and its branches of collaterals form the internal-external relationship of meridians, and have a special relationship with the skin connecting it to the meridian network.

Superficial Collaterals

Tiny branches of the divergent collaterals.

Tertiary Collaterals

Very superficial branches of the superficial ones.

12 Cutaneous Zones

Divisions of the body surface along the 12 meridians and their specific collaterals. They are included in the areas supplied by the 12 meridians, and manifest pathological conditions of those meridians.

Together, these networks are likened to warps of cloths penetrating deeply to the body and connecting with the zang and fu organs, the sense organs, openings, pores, tendons, bones and muscles. Different muscle groups are controlled by the conjoint meridians that pass through them.

‘Extraordinary Vessels’

Vessels that have no points of their own but are integrated fields governing the most fundamental actions such as protection, digestion, assimilation, incorporation, discharge, storage, distribution and dissolution.

Expositions of the Extra 8 vessels by Li Shi Zhen (1518-1593), an eminent figure in Chinese Medical history, emphasize its functional dynamics as an inseparable part of the meridian anatomy and urge practitioners to fully grasp the reality of alchemy by these extra 8 vessels for a complete understanding of pathology, disease and spiritual concepts of our destined purpose. These vessels include chong, ren, du, yin and yang wei, yin and yang qiao and dai.



**ESSENTIALS OF TRADITIONAL
CHINESE MEDICINE
PART 1: YIN-YANG**

TAIJI & THE FIRST CORRESPONDENCES

SUPREME VOID / CAUSE

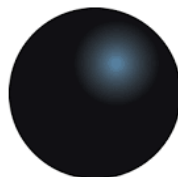

ORIGIN OF CREATION –
TAIJI BEGINS TO MOVE

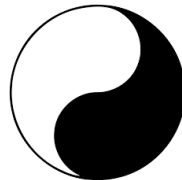

GENERATES MOVEMENT,
LIGHT, SOUND THAT BURSTS
INTO THE CATEGORIES OF
YIN & YANG

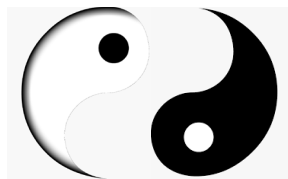

SOLIDIFIES INTO ALPHA
(YANG) OMEGA (YIN) AND
ETERNAL VOID



YANG



YIN

1ST CORRESPONDENCES

Light	Left
Sun	Immaterial
Brightness	Produces Energy
Activity	Generates
Heaven	Non-substantial
Round	Energy
Time	Rising
East	Above
South	Fire

1ST CORRESPONDENCES

Darkness	Right
Moon	Material
Shade	Produces Form
Rest	Grows
Earth	Substantial
Flat	Matter
Space	Contraction
West	Below
North	Water

THE FOUR SEASONS

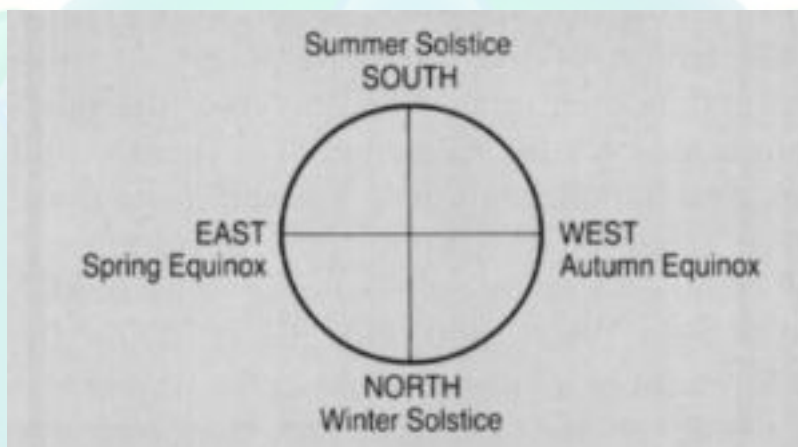

- Spring = Yang within Yin = growth of Yang
- Summer = Yang within Yang = maximum Yang
- Autumn = Yin within Yang = growth of Yin
- Winter = Yin within Yin = maximum Yin

THE FOUR ASPECTS OF THE YIN-YANG RELATIONSHIP



1. Opposition
2. Interdependency
3. Mutual Consuming
4. Inter-Transformation

The Opposition of Yin and Yang

Yin and Yang are opposite stages either of a cycle or of states of aggregation.

However, the opposition is relative, not absolute; nothing is totally Yin or totally Yang.

Everything contains the seed of its opposite.

Yin or Yang quality of something is not really intrinsic, but only relative to something else.

Thus, one cannot absolutely say that something “is Yang” or “is Yin”.

Yin and Yang are never present in a static 50/50 proportion, but in a dynamic and constantly changing balance.

Reference: homeostasis

The Interdependence of Yin and Yang

Although Yin and Yang are opposite, they are also interdependent: one cannot exist without the other.

Day is opposite to night, there cannot be activity without rest, energy without matter or contraction without expansion.

The Mutual Consumption of Yin and Yang

Yin and Yang are in a constant state of dynamic balance, maintained by continuous adjustment of the relative levels of Yin and Yang.

When either Yin or Yang are out of balance, they necessarily affect each other and change their proportion and so achieve a new balance.

The Four Possible States of Imbalance

- A) Excess of Yin
- B) Excess of Yang
- C) Weakness of Yin
- D) Weakness of Yang

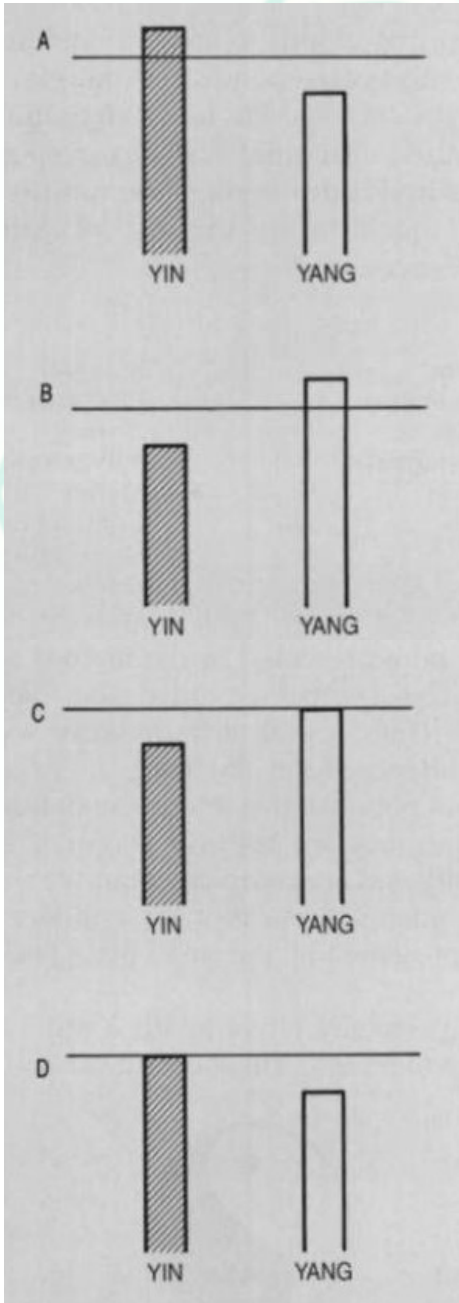

A) When Yin is excess, it induces a decrease of Yang, i.e. the excess of Yin consumes Yang.

B) When Yang is excess, it induces a decrease of Yin, i.e. the excess of Yang consumes Yin.

C) When Yin is weak, Yang is in apparent excess.

D) When Yang is weak, Yin is in apparent excess.

Excess of Yin and Weakness of Yang may appear the same, but they are not. What is primary and what is secondary?

In Excess of Yin, this is primary; the excess of Yin consumes the Yang.

In case of Weakness of Yang, this is primary; Yin is in apparent excess. It looks like it is in excess, but is only relative to the deficiency of Yang.

The same applies to Excess of Yang and weakness of Yin.

The Inter-Transformation of Yin & Yang

Yin and Yang are not static, but actually transform into each other.

This change only occurs at a certain stage of development of something.

Summer changes into Winter, day changes into night, life into death, happiness into unhappiness, heat into cold and vice versa.

APPLICATION OF YIN-YANG TO MEDICINE



- The whole of Chinese Medicine can be reduced to the basic and fundamental theory of Yin and Yang.
- Every physiological process and every symptom or sign can be analyzed in the light of the Yin-Yang theory.

Ultimately, every treatment modality is aimed at one of these four strategies:

1. To tonify (supplement) Yang
2. To tonify (supplement) Yin
3. To eliminate excess Yang
4. To eliminate excess Yin

FIVE ASPECTS OF YIN-YANG RELATIONSHIP	APPLICATION OF YIN-YANG TO MEDICINE	
<p>OPPOSITION: All things have Yin and Yang aspects</p>	YANG	YIN
	Exterior	Interior
	Heat	Cold
	Excess	Deficiency
	Restless	Quiet
	Acute	Chronic
	Rapid Changes	Lingering Disease
	Stretch Out	Curl Up
	Red Face	Pale Face
	Coarse Breathing	Shallow Breathing
	Thirst	No Thirst
	<p>INTER-DEPENDENCE: Yin and Yang cannot exist without the other</p>	<p>The Yin organs depend on The Yang organs to produce Qi and Blood.</p>
<p>MUTUAL-CONSUMING: Yin and Yang are in a constant state of change for preserving the balance</p>	<p>The Yang organs depend on the Yin organs for their nourishment deriving from Blood and Essence.</p>	
<p>INTER-TRANSFORMATION: Yin and Yang can change into one another</p>	<p>Excess of Yin: Excess Cold (Interior/Exterior) in the body consumes the Yang, especially SP Yang (FULL-COLD)</p>	
<p>INFINITE DIVISIBILITY: Yin and Yang aspects can be further divided into Yin-Yang</p>	<p>Excess of Yang: Heat (exterior/interior) consumes the body fluids and leads to dryness. (FULL-HEAT)</p>	
<p>INTER-TRANSFORMATION: Yin and Yang can change into one another</p>	<p>Consumption of Yang: The decrease of Yang energy leads to symptoms of a relative excess Yin, such as feelings of cold and chilliness. (EMPTY-COLD)</p>	
<p>INFINITE DIVISIBILITY: Yin and Yang aspects can be further divided into Yin-Yang</p>	<p>Consumption of Yin: The decrease of Yin leads to symptoms of a relative excess Yang, such as feelings of heat. (EMPTY-HEAT)</p>	
<p>INFINITE DIVISIBILITY: Yin and Yang aspects can be further divided into Yin-Yang</p>	<p>Exterior Cold (Yin) can invade the body and, after a time, it can easily change into heat (Yang)</p>	
<p>INFINITE DIVISIBILITY: Yin and Yang aspects can be further divided into Yin-Yang</p>	<p>Excess Heat (Yang) can damage the body fluids and lead to deficiency of fluids (Yin).</p>	
<p>INFINITE DIVISIBILITY: Yin and Yang aspects can be further divided into Yin-Yang</p>	<p>Deficiency of Spleen-Yang (Yin) can lead to excess of dampness (Yang)</p>	
<p>INFINITE DIVISIBILITY: Yin and Yang aspects can be further divided into Yin-Yang</p>	<p>In the body, the front of the trunk is Yin compared with the back, but the front can be divided further so that the abdomen is Yin in relation to the chest.</p>	

YIN-YANG AND THE BODY STRUCTURE

Every part of the human body has a predominantly Yin or Yang character, and this is important in clinical practice.

It must be emphasized, however, that this character is only relative.

For example, the chest area is Yang in relation to the abdomen (because it is higher), but Yin in relation to the head.

YIN-YANG AND THE BODY STRUCTURE	
Yang	Yin
Superior	Inferior
Exterior	Interior
Posterior	Anterior
Lateral	Medial
Back	Front (chest-abdomen)
Function	Structure
Head	Body
Exterior (skin-muscles)	Interior (organs)
Above the waist	Below the waist
Yang organs	Yin Organs
Function of Organs	Structure of organs
Qi	Blood-Body Fluids
Defensive Qi	Nutritive Qi

Basic Yin-Yang Qualities in the Clinical Practice

BASIC YIN-YANG QUALITIES IN THE CLINICAL PRACTICE	
Yang	Yin
Fire	Water
Hot	Cold
Restless	Quiet
Dry	Wet
Yang	Yin
Hard	Soft
Excitement	Inhibition
Rapidity	Slowness
Non-substantial	Substantial
Transformation, Change	Conservation, Storage

Clinical Signs Associated with Yin-Yang

Clinical Signs Associated with Yin-Yang	
Yang	Yin
Acute Disease	Chronic Disease
Rapid Onset	Gradual onset
Rapid pathological changes	Lingering disease
Heat	Cold
Restlessness, insomnia	Sleepiness, listlessness
Throws off bedclothes	Likes to be covered
Likes to lie stretched	Likes to curl up
Hot limbs and body	Cold limbs and body
Red face	Pale face
Likes cold drinks	Likes hot drinks
Loud voice, talks a lot	Weak voice, won't talk
Coarse breathing	Shallow, weak breathing
Thirst	No thirst
Scanty-dark urination	Profuse-pale urination
Constipation	Loose stools
Red tongue yellow coat	Pale tongue
Full pulse	Empty pulse



SUMMARY: RAINBOWFIRE

The harmony of balance of yin-yang determines our health.

We experience the wealthy substantial vitality within its states when its phases or relationships within our biology follow the natural rhythms of yin-yang.

Disease occurs as an expression of the imbalance of yin and yang. The separation of forces between yin and yang leads to gradual decay and diminishment of this vitality that will eventuate in the death of the body.

Our motivation and the primary motivation for traditional Chinese medicine is to adjust yin and yang, restoring relative balance to achieve optimal health and vitality.



**ESSENTIALS OF TRADITIONAL
CHINESE MEDICINE
PART 2: THE FIVE
ELEMENTS**

THE FIVE ELEMENTS:

Introduction

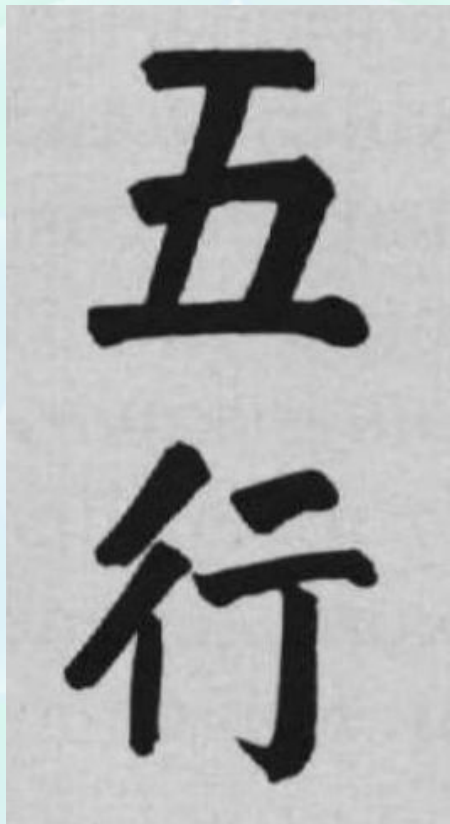

- Together with the theory of Yin-Yang, the theory of the 5 Elements constitutes the basis of Chinese medical theory.
- The five Elements are not basic constituents of Nature, but five basic processes, qualities, phases of a cycle or inherent capabilities of change of phenomena.
- Some authors use an alternate translation, “Five Phases”, which is closer to the original term, Wu Xing

FIVE ELEMENT THEORY

The theory of the 5 Elements was developed by the same philosophical school that developed the theory of Yin-Yang, i.e. the “Yin-Yang School”, sometimes also called the “Naturalist School”.

One could say that the philosophers of the Naturalist School developed a primitive natural science and occupied a respected social position comparable to that of modern scientists today.

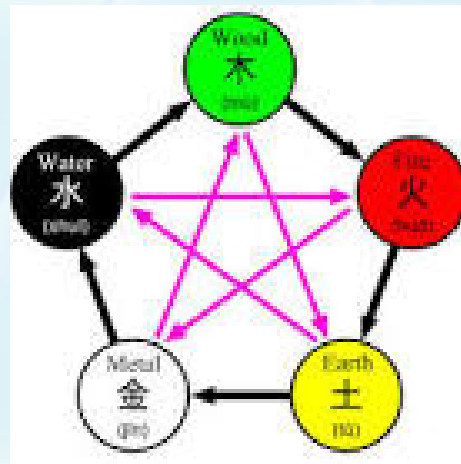

Five Elements as Basic Qualities

- “...Water moistens downwards, Fire flares upwards, Wood can be bent and straightened, Metal can be moulded and can harden, Earth permits sowing, growing and reaping.
- That which soaks and descends [Water] is salty, that which blazes upwards [Fire] is bitter, that which can be bent and straightened [Wood] is sour, that which can be moulded and become hard [Metal] is pungent, that which permits sowing and reaping [Earth] is sweet”. - from the “Shang Shu”

Five Elements as Movements

- The 5 Elements also symbolize five different directions of movement of natural phenomena. Wood represents expansive, outward movement in all directions, Metal represents contractive, inward movement, Water represents downward movement, Fire represents upward movement and Earth represents neutrality or stability.

Five Elements as Stages of a Seasonal Cycle

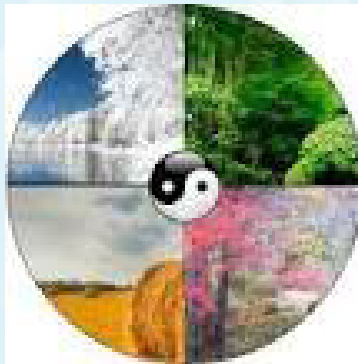

- Each of the 5 Elements represents a season in the yearly cycle.
- Wood corresponds to Spring and is associated with birth, Fire corresponds to Summer and is associated with growth, Metal corresponds to Autumn and is associated with harvest, Water corresponds to Winter and is associated with storage, Earth corresponds to the late season and is associated with transformation.

FIVE ELEMENT CORRESPONDENCES

FIVE ELEMENT CORRESPONDENCES					
ELEMENT	WOOD	FIRE	EARTH	METAL	WATER
SPIRIT	HUN (ETHEREAL SOUL)	SHEN (MIND)	YI (INTELLECT)	PO (CORPOREAL SOUL)	ZHI (WILL POWER)
YIN ORGAN	LV Liver	HT Heart	SP Spleen	LU Lung	KD Kidney
YANG ORGAN	GB Gallbladder	SI Small Intestine	ST Stomach	LI Large Intestine	UB or BL Urinary bladder
BODY TISSUE	Tendons/Nails	Blood Vessels	Muscles	Skin	Bones/Joints
BODY FLUIDS	Tears	Sweat	Saliva	Mucus	Urine
SENSE	Eyes/Sight	Tongue/Taste	Mouth/Lips/Speech	Nose/Smell	Ears/Hearing
UNBALANCED EMOTION	Anger	Depression/ Anxiety/ Excitability	Worry	Grief/Sadness	Fear
BALANCED EMOTION	Benevolence/Patience	Joy	Love/Compassion	Courage	Calmness
FINGER	Index	Middle	Thumb	Ring	Little
TASTE	Sour	Bitter	Sweet	Pungent	Salty
COLOR	Green	Red	Yellow	White	Blue
WEATHER	Windy	Hot	Damp	Dry	Cold
SEASON	Spring	Summer	Change of Season	Autumn	Winter
DIRECTION	East	South	Central	West	North
PHASE	New Yang	Full Yang	Yin/Yang Balance	New Yin	Full Yin
ENERGY	Generative	Expansive	Stabilizing	Contracting	Conserving

FIVE ELEMENT INTERRELATIONSHIPS

- Essential to the very concept of the 5 Elements are the various interactions among them.
- Thirty-six different arrangements of the 5 Elements are mathematically possible. The most common ones are five.

The Generating Sequence

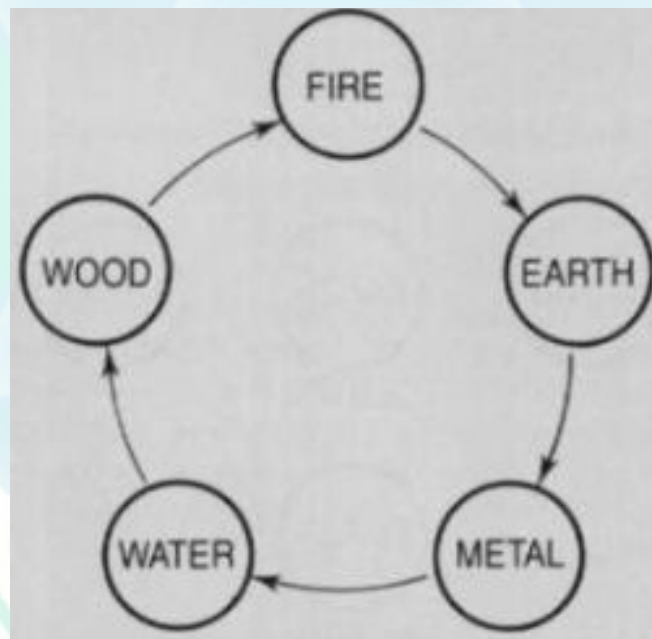

- In this sequence each Element generates another and is generated by one.
- Wood generates Fire, Fire generates Earth, Earth generates Metal, Metal generates Water and Water generates Wood.
- Thus, for example, Wood is generated by Water, and it generates Fire. This is sometimes expressed as “Wood is the Child of Water and the Mother of Fire”

The Controlling Sequence

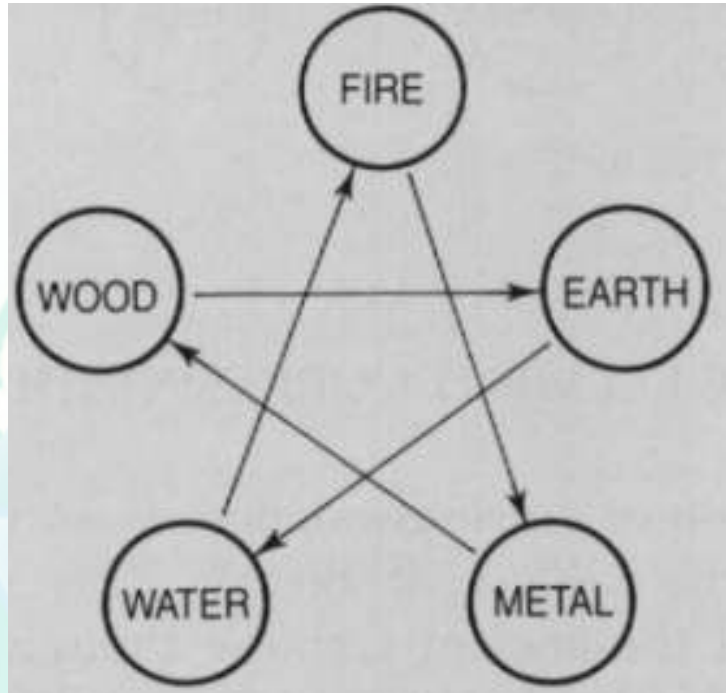

- In this sequence each Element controls another and is controlled by one.
- Thus, Wood controls Earth, Earth controls Water, Water controls Fire, Fire controls Metal and Metal controls Wood. For example, Wood controls Earth, but is controlled by Metal.
- Sometimes the “controller” element is referred to as the “Grandmother”.
- The controlling sequence ensures that a balance is maintained among the 5 Elements.
- There is also an interrelationship between the Generating and the Controlling sequences.
- For example, Wood controls Earth, but Earth generates Metal, which controls Wood.
- Furthermore, on the one hand Wood controls Earth, but on the other hand it generates Fire, which, in turn, generates Earth.
- Thus a self-regulating balance is kept at all times.

Sequence and Relationships

SEQUENCE AND RELATIONSHIPS		
SEQUENCE	PHYSIOLOGY	PATHOLOGY
SHENG	Generating (=Promoting)	Failure to Nourish Son
		Draws from Mother
KO	Controlling (=Acting)	Overacting (=Over-acting)
		Insulting (=Counter-acting)



**ESSENTIALS OF TRADITIONAL
CHINESE MEDICINE
PART 3: VITAL
SUBSTANCES**

THE VITAL SUBSTANCES:

Introduction

- Chinese Medicine sees the working of the body and mind as the result of the interaction of certain vital substances.
- These substances manifest in varying degrees of “substantiality”, so that some of them are very rarefied and some totally non material.
- At the basis of all is Qi: all the other vital substances are but manifestations of Qi in varying degrees of materiality, ranging from the completely material, such as Body Fluids, to the totally immaterial, such as the Mind (Shen).

VITAL SUBSTANCES					
THE VITAL SUBSTANCES	Jing (Essence)	Qi	Blood	Body Fluids	Shen (Spirit)
MAJOR ORGAN	KD	LU	LV	SP	HT

The Vital Substances are:

- Qi
- Blood
- Essence (Jing)
- Body Fluids
- Some sources include Mind or Spirit (Shen)

FUNCTIONS OF ESSENCE (*JING*)

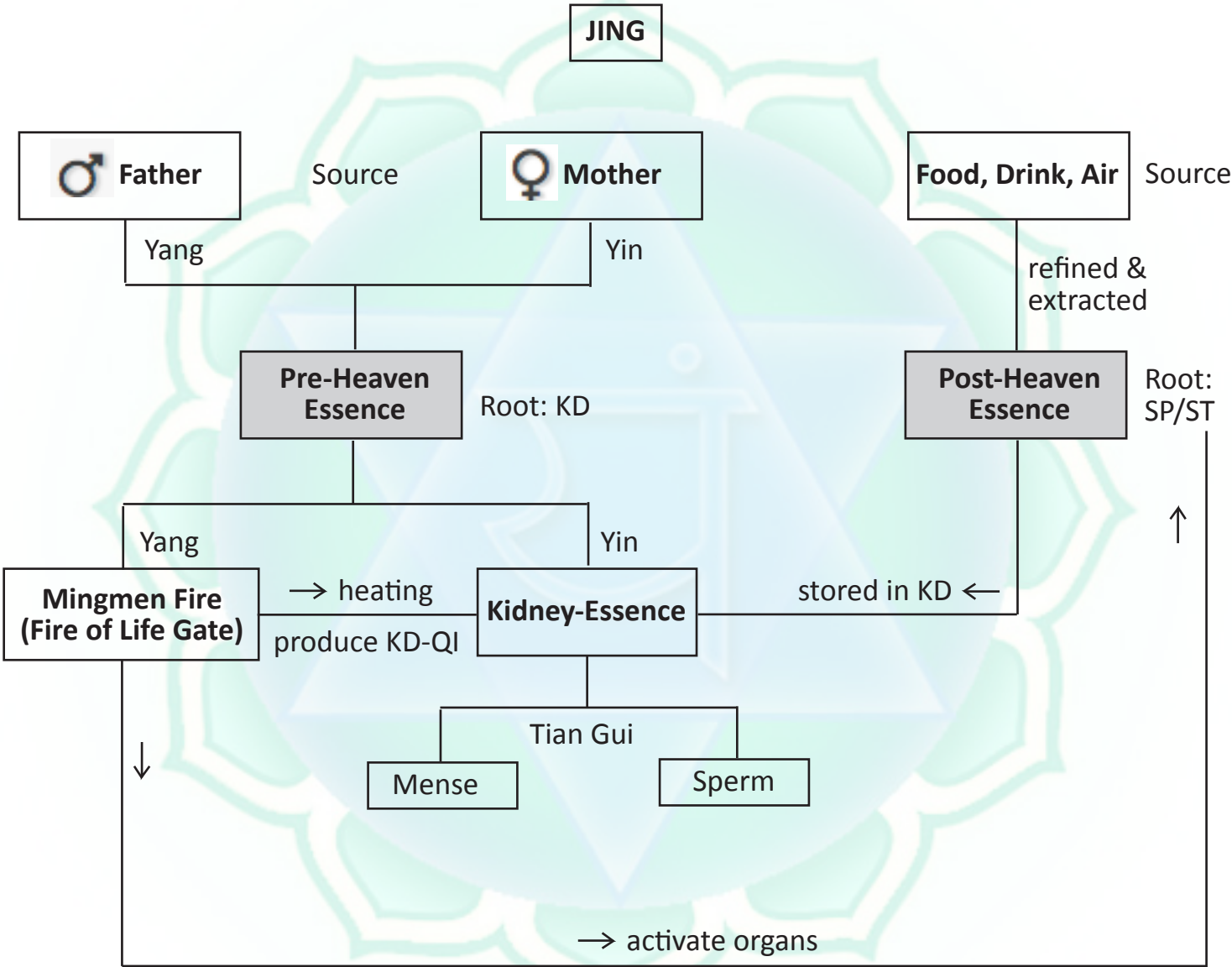

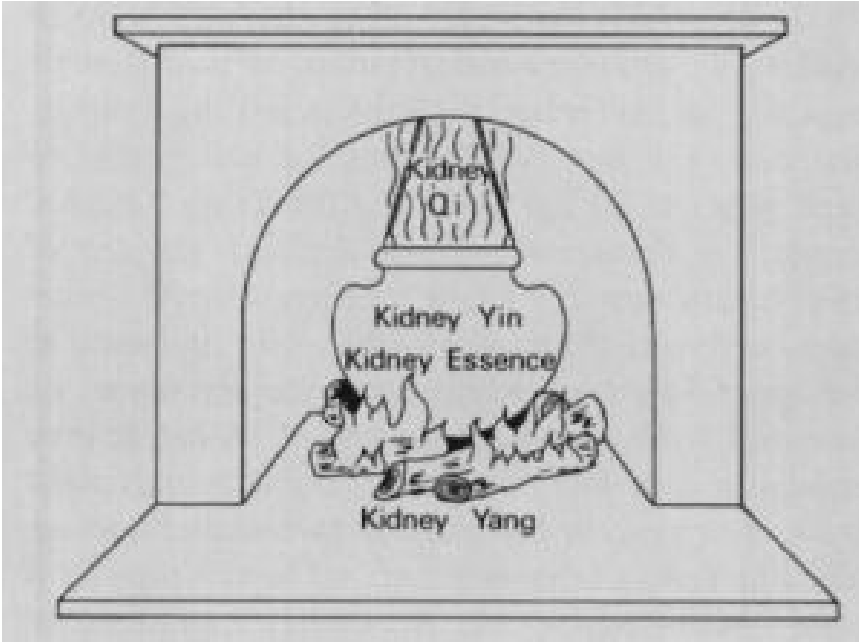

Functions of Essence

1. Growth, reproduction and development
2. Basis of Kidney-Qi
3. Producer of Marrow
4. Basis of constitutional strength
5. Basis for the “Three Treasures” (Essence, Qi, Mind)

The Three Treasures

THE THREE TREASURES						
THE THREE TREASURES		ORGAN	3 LEVELS	POINTS	CHAKRAS	IMAGE
SHEN	Vitality behind Jing and Qi	HT	Heaven	Yintang	Brow Chakra	
QI	Ability to activate and move	SP/ST	Human	RN17	Heart Chakra	
JING	Source of Life	KD	Earth	RN4	Sacral Chakra	

QI

As we have discussed, Qi takes various forms in the body fulfilling a variety of functions.

Let us now discuss the various forms of Qi.

Classification and Production of Qi

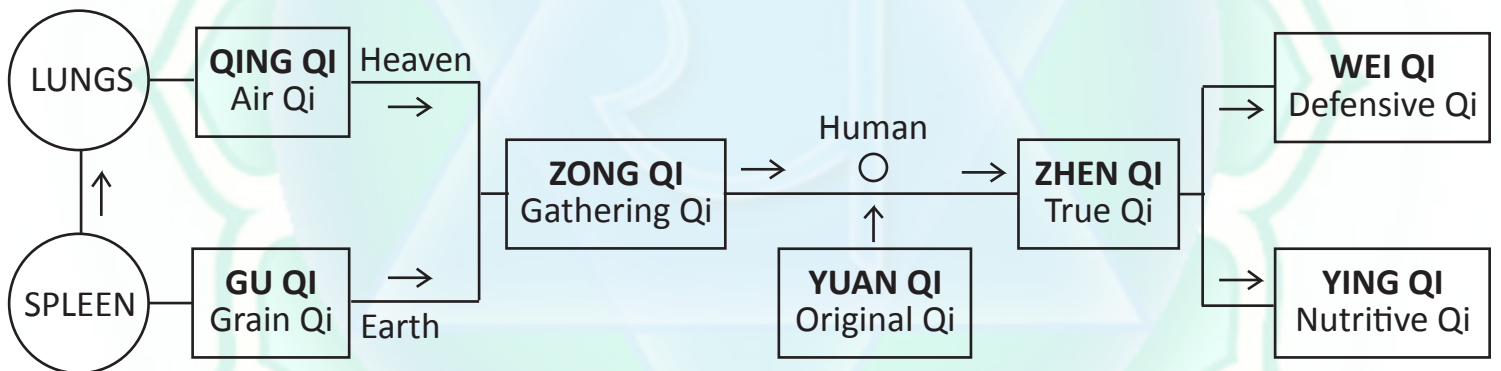

Basic Functions of *Qi*

1. **Transforming/Activities of Qi**
2. **Transporting/Promoting**
3. **Holding/Checking**
4. **Raising/Nourishing**
5. **Protecting/Defensive**
6. **Warming**

1. **Transforming:** Spleen-Qi transforms food into Food-Qi, Kidney-Qi transforms fluids, BL-Qi transforms urine, Heart-Qi transforms Food-Qi into Blood.
2. **Transporting:** Spleen-Qi transports Food-Qi, Lung-Qi transports fluids to the skin, Kidney-Qi transports Qi upwards, Liver-Qi transports Qi in all directions, Lung-Qi transports Qi downwards.
3. **Holding:** Spleen-Qi holds the Blood in the blood vessels, Kidney-Qi and Bladder-Qi hold urine, Lung-Qi holds sweat.
4. **Raising:** Spleen-Qi raises the organs, Kidney-Qi rises upwards.
5. **Protecting:** Lung-Qi protects the body from exterior pathogenic factors.
6. **Warming:** This is a function of Yang-Qi. Both Spleen-Yang and Kidney-Yang, especially the latter, have the function of warming the body.

Pathology of Qi

Qi pathology can manifest in four different ways:

1. Qi deficient: Qi can be deficient from various causes. This is so especially of the Qi of the Spleen, Lungs or Kidneys.
2. Qi sinking: If Qi is deficient it can sink, causing prolapse of the organs. This applies mostly to Spleen-Qi.
3. Qi stagnant: Qi can fail in its movement and stagnate. This applies mostly to Liver-Qi.
4. Qi rebellious: Qi can flow in the wrong direction: this is called “rebellious Qi”. For example, Stomach-Qi failing to descend and flowing upwards, causing nausea or vomiting.

Pathological Influences (Example: LV)

LIVER	OTHER ORGANS		
LV DEFICIENCY (WOOD)	Fire	-	HT drawing from LV
	Earth	+	SP insulting LV
	Metal	+	LU overacting on LV
	Water	-	KD fail to nourish LV
LV EXCESS (WOOD)	Fire	•	•
	Earth	-	LV overacting on SP
	Metal	-	LU failing to control LV
	Water	-	LV drawing from KD

Mingmen, Yuan Qi and Yuan-Source Points

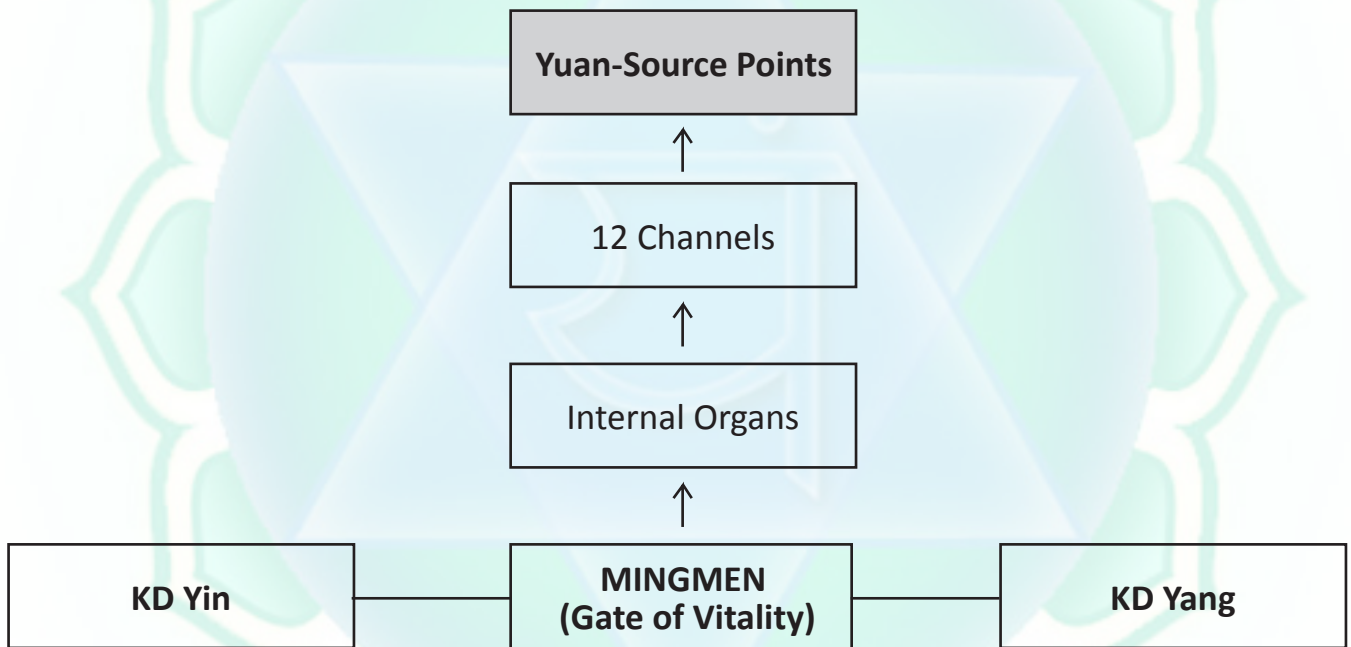

Axis, Root and Outer Wheel

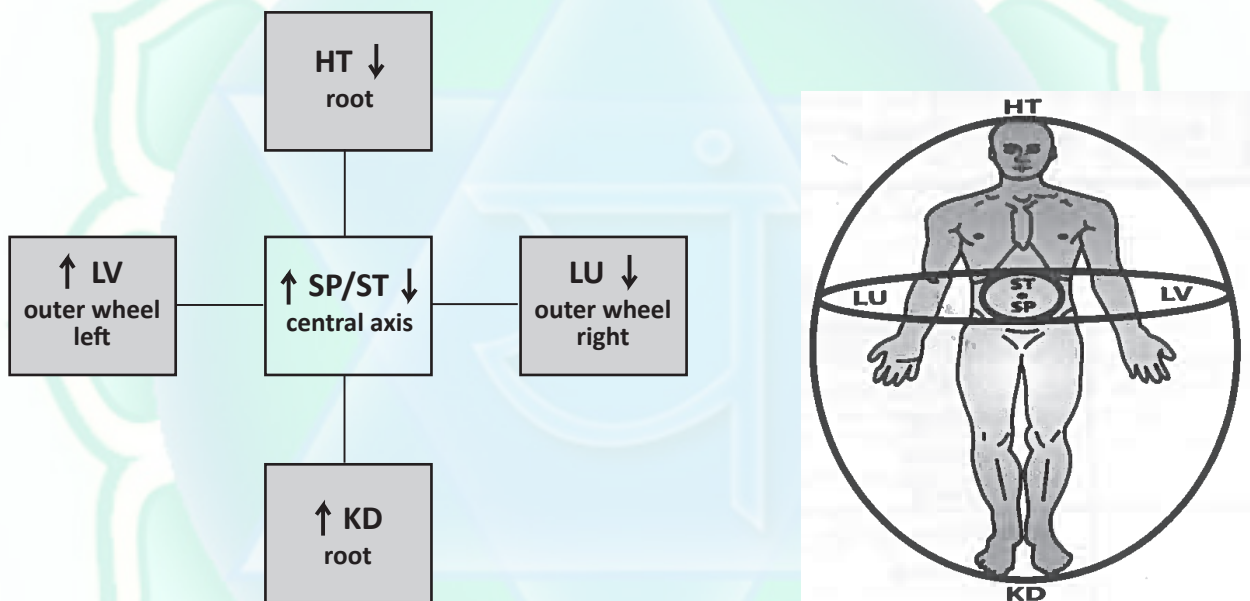

The Liver and Lungs as the Outer Wheel

The Liver is on the left and its Qi rises, the Lungs are on the right and its Qi descends.

Being “on the left” or “on the right” should not be interpreted in a strict anatomical sense, but in relation to the 5-Element scheme which places Wood (Liver) on the left and Metal (Lungs) on the right.

The Heart and Kidneys as the Root

The Heart shelters the Mind and pertains to Fire; the Kidneys store Essence and pertain to Water.

The polarity of Heart and Kidneys is the fundamental polarity between Fire and Water.

The Fire of the Heart descends to the Kidneys to warm them; the Water of the Kidneys rises to the Heart to nourish its Yin aspect.

The descending of the Fire of the Heart and ascending of the Water of the Kidneys keeps the fundamental balance between Fire and Water, Yang and Yin, Above and Below.

There is a direct connection between Heart and Kidneys and the two must communicate with each other and be harmonized.

The book “Wu’s Collected Medical Works” (1792) says: “The Heart pertains to Fire but there is Water within Fire; the Kidneys pertain to Water but there is Fire within Water. Fire governs Water and Heart-Qi descends. Water is the source of Fire and Kidney-Qi ascends. If Water does not ascend, disease ensues: this is due to Kidney-Yang deficient unable to raise Water upwards. If Fire does not descend, disease ensues: this is due to Heart Yin deficient unable to lower Fire downwards.”

BLOOD

- Blood in Chinese Medicine has a different meaning than in Western Medicine.
- In Chinese Medicine, Blood is itself a form of Qi, a very dense and material one, but Qi nevertheless.
- Blood is inseparable from Qi itself, Qi infuses life into Blood; without Qi, Blood would be an inert fluid.

Source

- Blood is derived mostly from the Food-Qi produced by the Spleen.
- The Spleen sends Food Qi upwards to the Lungs, and from there it is sent to the Heart, where it is transformed into Blood

Source of Blood

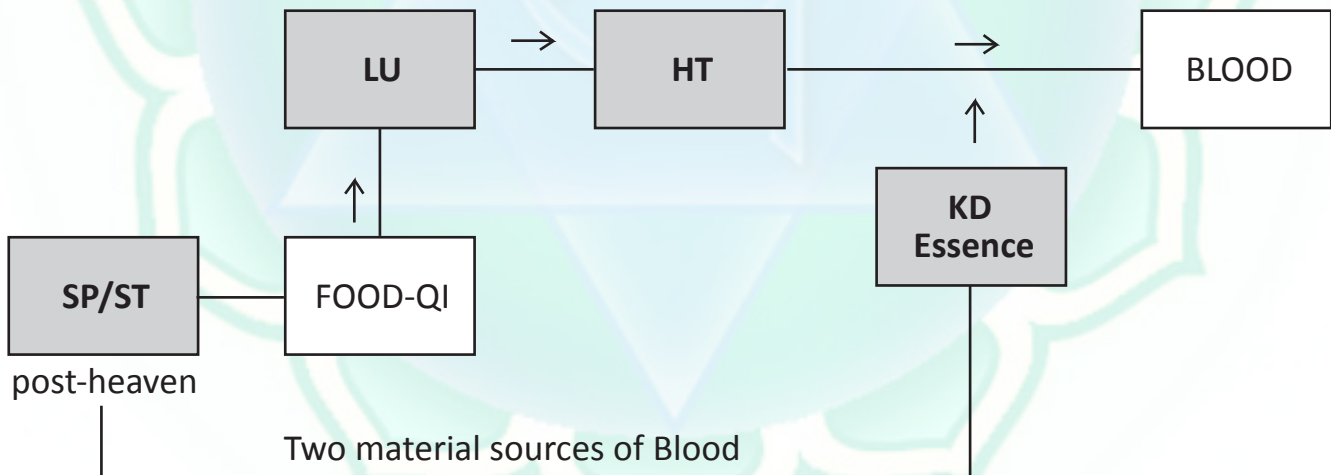

The previous figure illustrates three aspects:

- a. The Spleen and Stomach are the main source of Blood;
- b. Lung-Qi plays an important role in pushing Food-Qi to the Heart: this is an example of the general principle that Qi makes Blood move;
- c. Food-Qi is transformed into Blood in the Heart: this is one aspect of the principle that the Heart governs Blood.

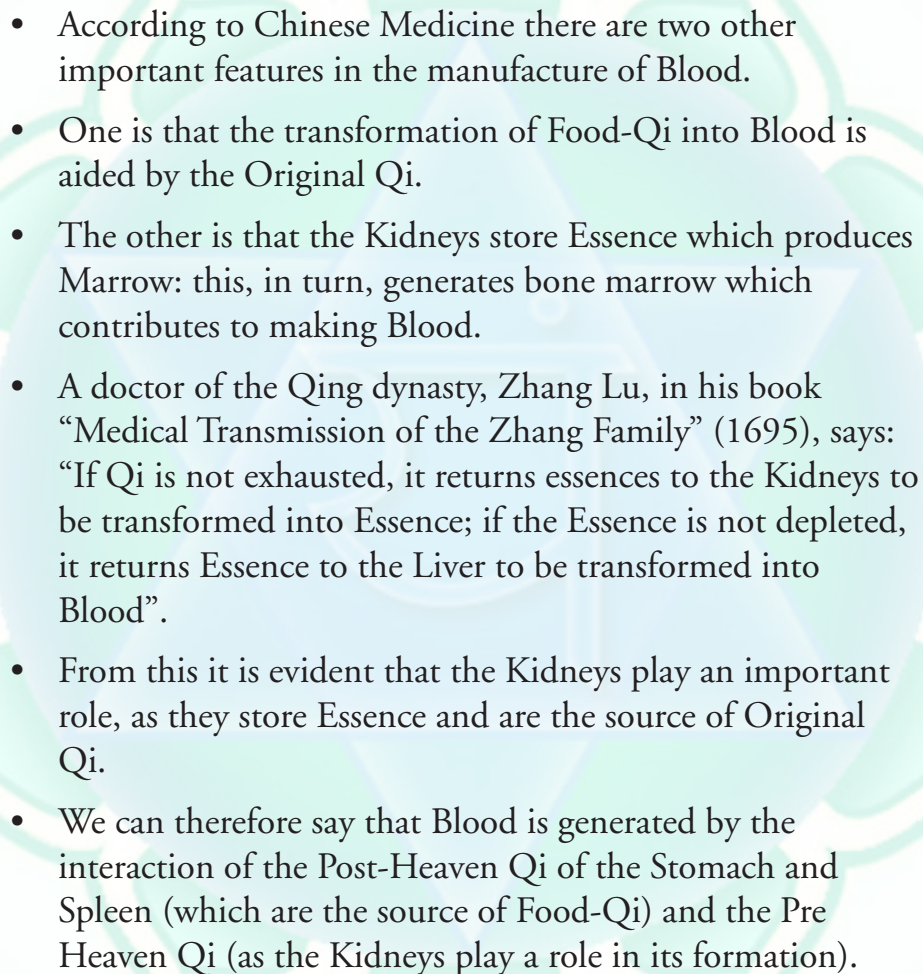
- 
- According to Chinese Medicine there are two other important features in the manufacture of Blood.
 - One is that the transformation of Food-Qi into Blood is aided by the Original Qi.
 - The other is that the Kidneys store Essence which produces Marrow: this, in turn, generates bone marrow which contributes to making Blood.
 - A doctor of the Qing dynasty, Zhang Lu, in his book “Medical Transmission of the Zhang Family” (1695), says: “If Qi is not exhausted, it returns essences to the Kidneys to be transformed into Essence; if the Essence is not depleted, it returns Essence to the Liver to be transformed into Blood”.
 - From this it is evident that the Kidneys play an important role, as they store Essence and are the source of Original Qi.
 - We can therefore say that Blood is generated by the interaction of the Post-Heaven Qi of the Stomach and Spleen (which are the source of Food-Qi) and the Pre Heaven Qi (as the Kidneys play a role in its formation).

Functions of Blood

- Nourishes the body
- Circulates with Nutritive Qi
- Moistens the body
- Houses the Mind
- Determines menstruation

Blood and Organs

HT	GOVERNS	→	BLOOD	responsible for Blood circulation
SP	MAKES	→		ensures that blood remains in the blood vessels
LV	STORES	→		nourishes sinews, moistens eyes, regulates uterus

Relationship Between Essence, Qi, Blood and Body Fluids

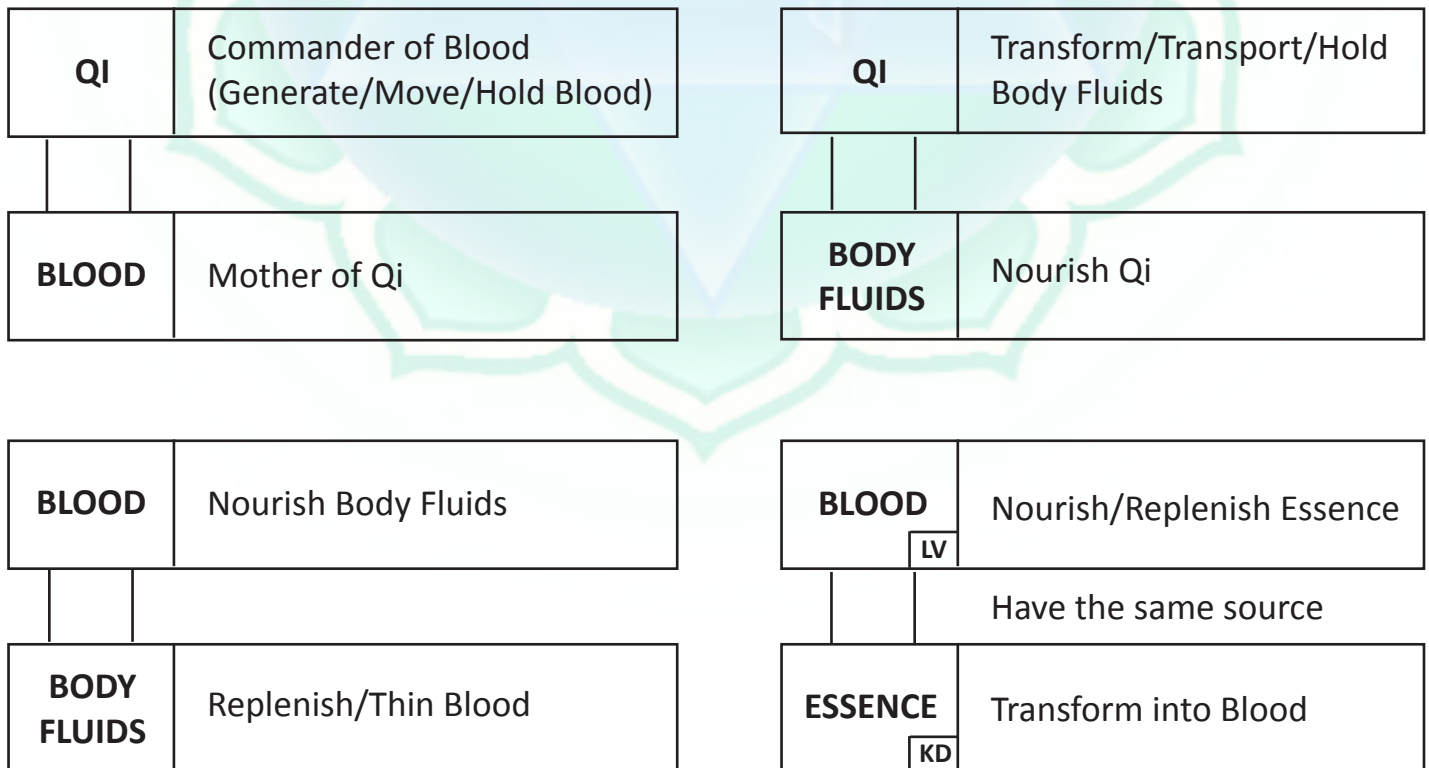

SHEN

Characteristics of Spirit

CHARACTERISTICS	PATHOLOGY	
	SHEN DISTURBANCE	FALSE SHEN
Physical appearance and color is bright	Patient is thin, emaciated	Sudden revival before death due to floating up of Yang Qi
Spirit of the eyes shows alertness and is shiny	Face is dull, color of organs is exposed	Yin and Yang separates- indicates end of life
Mind is clear, clear speech, normal behavior	Mind is not clear, confused, body movement is erratic	From chronic disease where essence is exhausted
Respiration is even and smooth	Speech is incoherent	
Appetite is good and bowel movements are normal	Respiration is uneven, shallow, short of breath	Very high fever will exhaust Yin
	Internal organs are exhausted	
	Prognosis is poor - patient is on downward trail	

Functions of Spirit

THE FIVE SPIRITS				OUTER BACK-SHU	FUNCTIONS
NAME	RESIDE IN	RESPONSIBLE FOR			
HUN	Ethereal Soul	LV	sleep, plans, projects, life aims, 'coming and going of Shen'	UB47 Door of the Ethereal Soul	Has a profound influence on a person's capacity of planning his or her life by rooting and steadying the Ethereal Soul
SHEN	Mind	HT	consciousness, thinking, affections, memory, sleep	UB44 Mind Hall	Mostly used for emotional and psychological problems related to the HT, i.e. anxiety, insomnia, depression
YI	Intellect	SP	thinking, memory, concentration	UB49 Thought Shelter	Tonifies the mental aspect of the SP, i.e. memory, concentration and capacity for study
PO	Corporeal Soul	LU	feelings, sensations	UB42 Door of the Corporeal Soul	Has a very soothing effect on the spirit and it nourishes Qi when this is dispersed by a prolonged period of sadness or grief
ZHI	Will Power	KD	will-power, drive, determination	UB52 Will Power Room	Strengthens will power and determination which are the mental-spiritual phenomena pertaining to the KD

Entering-Exit of Qi Between Shen & Hun

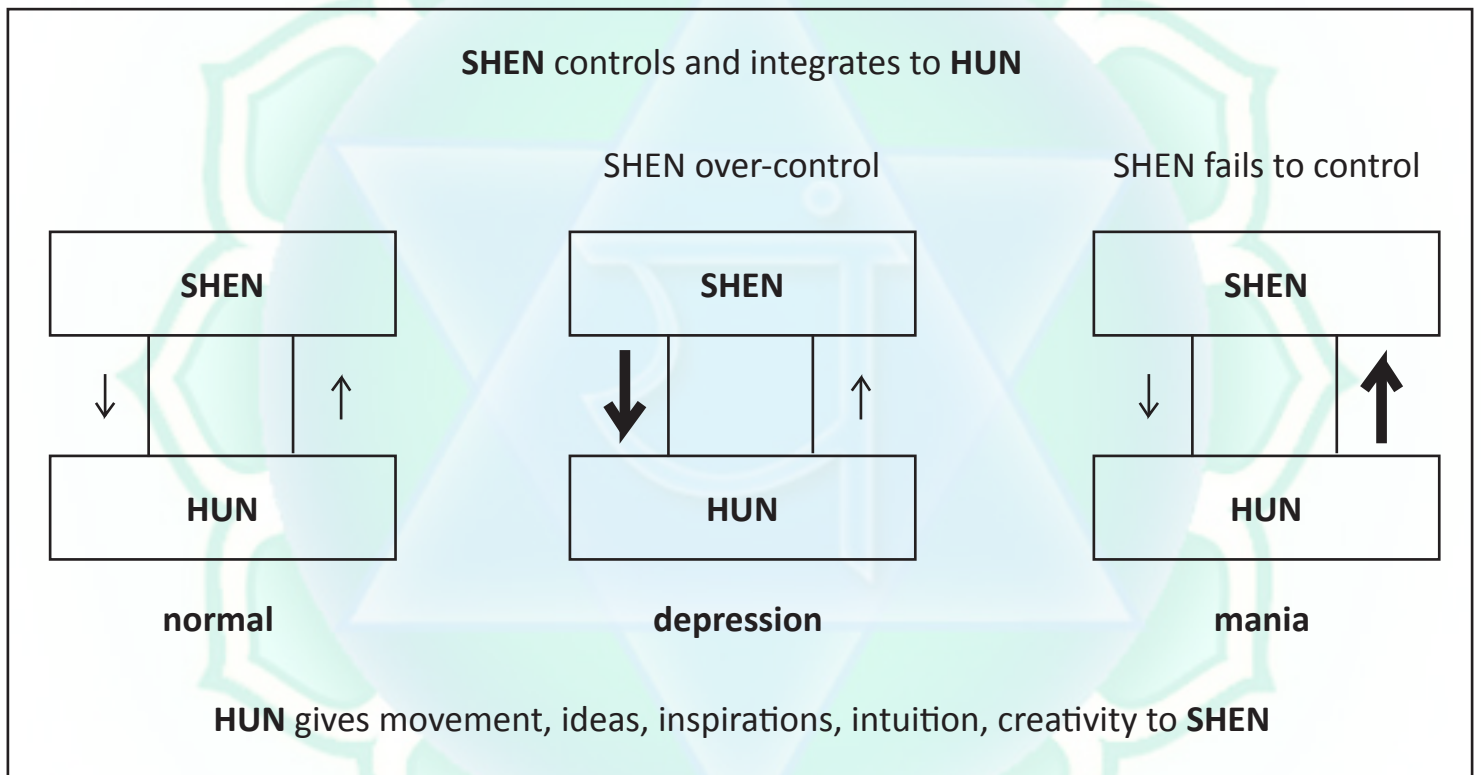

CONNECTIVE TISSUE (SAN JIAO OR INTERSTITIUM)

The Connective Tissue Issue

- What are the Structures and Functions of the various parts?
- What does each part do?
- How does bodywork affect these mechanisms?

The image shows the Chinese characters for 'San Jiao' (三焦) in a bold, black, calligraphic style. The characters are '三' (San) and '焦' (Jiao). The 'San' character is on the left and consists of three horizontal strokes. The 'Jiao' character is on the right and is more complex, featuring a curved top stroke and four dots at the bottom, which are symbolic of a phoenix rising from flames.

Looking at the Lattice

- The Triple Burner or San Jiao is the eastern equivalent to the western anatomy of connective tissue. Let's first look at the Chinese characters to understand the organ:
- “San” means three
- “Jiao” is depicted by the body of a bird with four dots indicating flames. This refers to a “phoenix rising” symbolism

San Jiao: Triple Burner

- The Triple Burner is an independent functional system based on the morphological structure of the internal organs and tissues. In fact it is a generalization of the physiological functions of the internal organs. The physiological functions of the Triple Burner include the following two aspects:
- A generalization of Yuan Qi (primordial Qi) and water passage- the Triple Burner serves as a transmitting system through which substances like the primordial Qi and water are transported and transmitted. Primordial Qi comes from the Kidneys and is the motivating force for all life activities. This Qi originates from the Kidneys and is distributed to all parts of the body to nourish and warm the viscera and the tissues so as to activate and promote the physiological functions of the other viscera and tissues. When primordial Qi is deficient the transportation of the San Jiao will not be smooth and leads to deficiency in certain areas of the body.
- When food is taken into the stomach and transported and transformed by the spleen, the water is transmitted upwards to the lung by means of regulating the water passage, where then the turbid parts are transmitted as water down to the kidneys. Such a continuous circulation maintains normal metabolism of water inside the body.

The lung is located in the upper Jiao, the spleen in the middle Jiao and the kidney is in the lower. It is the San Jiao that organizes these three organs into a system for transmitting and metabolizing water. An important function of the San Jiao is that when obstructed the functions of the lung, the spleen and the kidney will certainly be affected.

- A generalization of the physiological functions of certain internal organs
- The generalization of the physiological functions of certain viscera with the San Jiao is mainly concerned with the digestion and absorption of food, with the distribution of food nutrients and metabolism of water.
- The 3 similes used to describe this function are that the upper Jiao is like fog, that is to say that the functions of the heart and lung to distribute food nutrients is like fog everywhere. The middle is denser describing the digestion and absorption of food as not only related to the spleen and the stomach but also to the liver and gall bladder. The lower is like sewer, that it is the function of the kidneys and bladder moving the turbid liquid downward and discharging it out of the body. If pathogenic factors invades the Triple Burner on any one of these levels functions of each Jiao will be affected leading to dysfunctions for the organs affected.

Triple Burner=San Jiao

	CAM	FCM
UPPER BURNER	Fog	Mist
MIDDLE BURNER	Froth	Maceration Chamber
LOWER BURNER	Drainage Ditch	Drainage Ditch

The vital role of Qi in the San Jiao pertains to the primordial Qi in the kidneys. It relates the transportation and life activities throughout the entire body by its warming, moving, protecting, transforming, holding and raising properties of Qi in the San Jiao. The pathogenic factors such as cold, heat, damp, wind and dry cause obstruction at the level of the San Jiao.

Connective Tissue Proper

“A fully fledged organ, if all the bones and organs of the body were removed, connective tissue proper would aptly hold the entire structure of the body together.”

-Juhan, Job's Body

Fibrils Arrangements/Fibroblasts

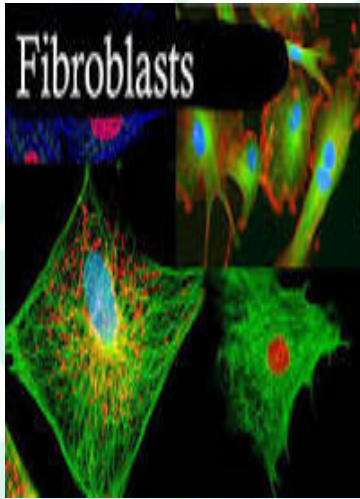

The most abundant protein structure are collagen fibrils. These structures take on the forms of ropes binding, shaping, investing, adhering, and fastening various organs from corneas to eye sockets, blood vessels to organ sheaths, tendons to ligaments and bone. These cellular arrangements called fibroblasts produce the fibrils and other fibers that is the principal active cell of connective tissue:

Connective tissue is the most abundant and diverse type of animal tissue. Animal tissue divides into four basic groups, which include epithelial tissue, muscle tissue, nerve tissue, and connective tissue. Similar to a framework of a house, connective tissue serves to provide structure, support, and protection throughout the human body.

Although connective tissue is diverse, all connective tissue consists of three main components:

1. Ground Substance
2. Fibers
3. Cells

Water Bags

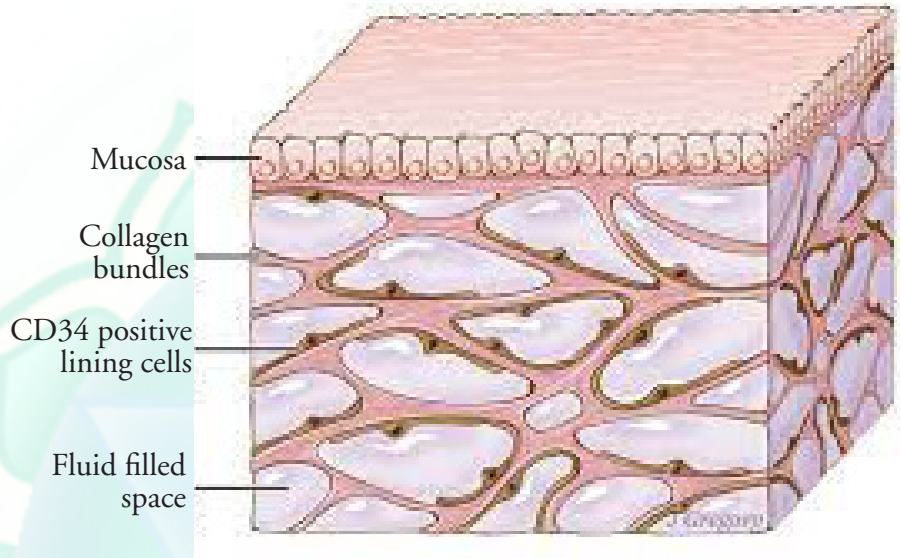

Together, the ground substance and fibers make up the extracellular matrix, which is the structural support of surrounding cells throughout the body.

Function

Connective Tissue provides:

- Resistance to stretch and tear
- Structural support
- Insulation
- Storage of body fuel
- A medium of intercellular exchange

“There are over 200 documented disorders of connective tissue. The etiology can include, autoimmune diseases, genetic disorders, cancers, rheumatoid arthritis or chronic-Bi-syndrome, inflammation leading to cartilage deterioration and bone. It classically presents in middle-aged women with symmetrical pain and swelling of the joints, manifesting as low-grade fevers, myalgias, malaise, night sweats and can affect a variety of organs throughout the body.”

Nezwek TA, Varacallo Physiology, Connective Tissue

Hydrogen Bonding and Thixotrophy

Fibroblasts, the most abundant cells in connective tissue, secrete hyaluronic acid and proteins into ground substance to give viscosity. These bonds are formed through hydrogen and oxygen radicals on individual strands of collagen. The hydrogen bonding action not only gives great strength to the collagen structures, over time, disuse, trauma and deficiency develops the actions of Thixotropy which condenses the fascia or connective tissue layers into asymmetrical patterns. These patterns can change due to the actions of Thixotropy which is the movement of collagen fibrils from gel to liquid-like states.

ASHIATSU AS BODYWORK MAGIC



The connective tissue lattice once shaped by the actions of hydrogen bonding and thixotropy may not be able to change without energy, movement and pressure applied to create new intercellular exchanges of Qi/Blood. In the system of *Eastern Ashiatsu* we are accessing the power of the meridian network or connective tissue proper via the Hara as an anchor. Doing so, we access the process of the spirit of life-force that's flowing through the organs, affecting its vital fluids and its connective tissue network or Jinlo. By attuning to the hara as an anchor, the tendons and musculatures literally becomes one. *Eastern Ashiatsu* is one of the most efficient ways to establish free movement to the various gelled and glued parts of the connective tissue proper. Without pressure, movement and eastern medical knowledge applied to the diseased parts, its mechanisms of pathology would continue its degredating behaviors of disharmony within the body.

**SUPINE:
HARA ABDOMINAL
ACTIVATING/
PACIFYING SEQUENCE**



RULES-OF-THUMB FOR BEGINNERS:

- PRACTICE THE PARENT-CHILD COMMUNICATION WHEN YOU BEGIN, AND ALWAYS END IN STILLNESS.
- ALLOW THE FOOT TO BE AS SENSITIVE AS YOUR HANDS BY RESONATING IN SILENCE BEFORE, DURING AND AFTER A SESSION, THUS REPOSING YOURSELF AND THE CLIENT IN STATE OF MEDITATION.

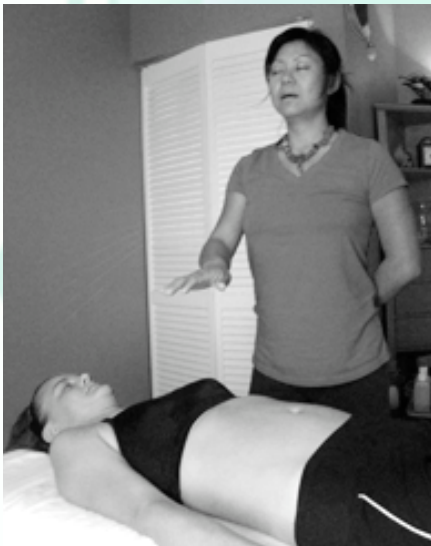

“AH” RESONANT BREATHING/HAND OVER HEART AND NAVEL



FULL BODY ROCKING



HAND OVER SOLAR PLEXUS - SET YOUR INTENTION, SEE THE SESSION COMPLETE AND IN HARMONY WITH THE UNIFIED FIELD, HONOR THE ANCESTORS, REPOSE YOURSELF AS A CHANNEL OF LIGHT, OPEN HEART AND HARA, ATTUNE TO 5-ELEMENTS

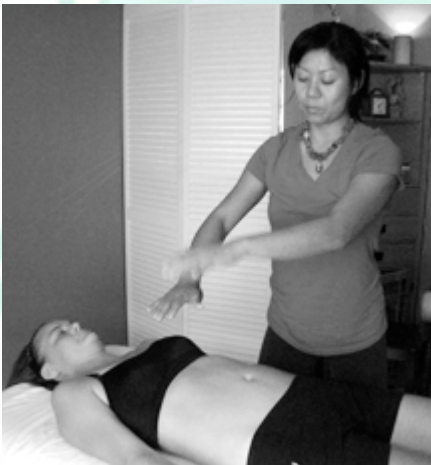

AURIC STROKING OVER NAVEL AND DOWN THE HIPS



SKIN-LEVEL STROKING OVER NAVEL AND DOWN THE HIPS



TISSUE-LEVEL STROKING (USE AROMATHERAPY
HERE; APPLY TO NAVEL BUTTON AND INVITE CLIENT
TO INHALE)



HAND TO 'HEAL' WAVES

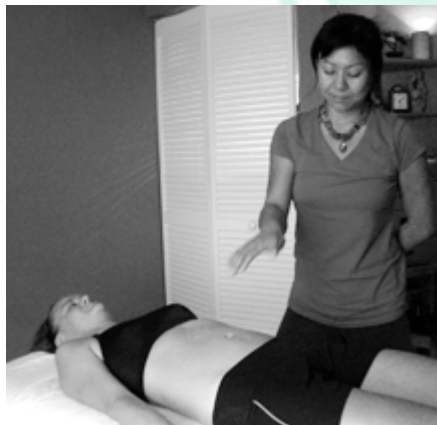

HAND OVER LOWER TAN TIEN QI BOUNCE



RAINBOW HAND CIRCLE OVER ENTIRE NAVEL



RELEASE VASTU USING LIGHT, SOUND, COLOR THERAPY



THUMB AND FORE/MIDDLE FINGER TO 'WIND THE MERIDIANS.' CHOOSE OR INTUIT WHICH MERIDIAN CV/REN/KIDNEY/SPLEEN/STOMACH OR WORK ON THE NINE ZONES



PALM CIRCLES OVER NAVEL



ACCENTUATION POINTS OVER RECTUS
ABDOMINUS



SUN/MOON



STILLNESS

**SUPINE:
BAREFOOT ROUTINE
ON LEGS**





ACKNOWLEDGE FOOT AND ANKLE MARMAS



BI-LATERAL COMPRESSION OVER FOOT (LATERAL HOLD)



BI-LATERAL COMPRESSION OVER FOOT (MEDIAL HOLD)



CHOOSE LEG (MEN/RIGHT, WOMEN/LEFT)

SUPINATE FOOT AND STRETCH ENTIRE LEG
MEDIALLY HOLDING AT ST-31 (INFERIOR TO THE
CREST OF HIP FLEXOR, AIIS)





**TM COMPRESSION OVER GALLBLADDER/STOMACH
NADI**



**SINGLE FOOT COMPRESSION OVER GB-34(JUST
BELOW THE EYE OF THE KNEE)**



**WHILE HOLDING GB-34, SKIN-LEVEL GLIDING
WITH CHILD FOOT DOWN THE COLLATERALS INTO
THE LATERAL MALLEOLUS**



**RELEASE AND COMPRESS GB-38(FOUR CUN
SUPERIOR TO THE MALLEOLUS JUST LATERAL TO
THE FIBULA)**



**ROLL THE LEG SO THE MEDIAL SIDE IS EXPOSED
AND COMPRESS SPLEEN NADI**



FEMORAL PULSE HOLD IN DOWNWARD FACING DOG POSITION

ADJUST BODY AND FACE TOWARDS THE FEET



MEDIAL COMPRESSION OVER THE CALCANEUS (K3/BLADDER/GALLBLADDER)

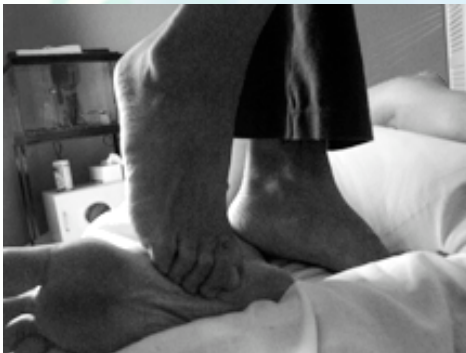

RELEASE ONE FOOT AND GTP (GREAT TOE PRESS) OVER ARCH POINTS OR HEEL COMPRESSION OVER SP-5



ADJUST FOOT TO OTHER SIDE AND REPEAT SEQUENCE TO THE OPPOSITE LEG

**SUPINE:
BENDED KNEE
SEQUENCE**





MOTHER FOOT HOLD OVER CALCANEUS



LFC OVER KIDNEY/SPLEEN NADI, UP THE CALF



LFC OVER THIGH UP TO MIDWAY



HEEL OVER SP-5 AND ARCH OF THE FOOT



ACCENTUATION POINT: SP-3 COMPRESSION

**PRONE:
BAREFOOT ROUTINE
ON LEGS**





SOLE TO SOLE



BI-LATERAL ANKLE STRETCH



BI-MEDIAL ANKLE STRETCH



GTP OVER 6 FOOT POINTS (CHOOSE FOOT)



COMPRESS AND DRAG TOWARDS THE TOES
ACKNOWLEDGING THE EXTRAORDINARY
POINTS OR EXIT POINTS OF THE FOOT WHILE
MOTHER FOOT CRADLED ALONG POSTERIOR
ASPECT OF ANKLE OVER K3

GENTLE AURIC STROKING WITH HAND OVER
THE ENTIRE LOWER EXTREMITY SURFACE TO
RELEASE VASTU

REPEAT WITH OPPOSITE FOOT

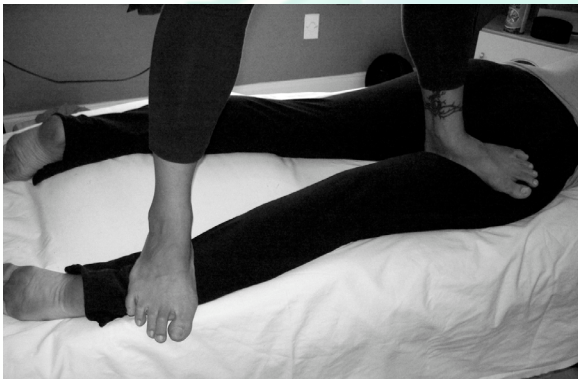

LFP (LOVING FOOT PRESS, TMP) OVER YIN
MERIDIANS: KIDNEY, SPLEEN, LIVER

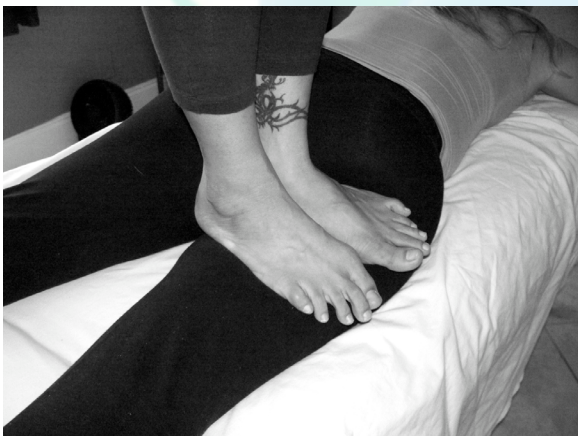

BI-FOOT COMPRESSION OVER POSTERIOR
FEMORAL CUTANEOUS ZONES, POSTERIOR
DIVISION OF S1, 2, 3



MOTHER FOOT OVER POSTERIOR INGUINAL
CREASE/UNDERNEATH ISCHIAL TUBEROSITY/
S1,2,3 (FLUSHES KIDNEY JING, RESTORES
KIDNEY YANG, REJUVENATES SACRAL PLEXUS,
HARMONIZES YIN/YANG OF THE LOWER LIMBS



GTP OVER GB 39 AND 40 STRAIGHT INTO THE HIP FLEXORS



GTP, LFC OVER GB NADI DOWN TO KNEES



HAVE RECIPIENT BEND HIS/HER KNEE AND HOLD OVER HEAD OF HAMSTRINGS ABOUT MIDWAY ABOVE THE POPLITEAL FOSSA OR FIND THE ASHI POINT

NOTES:

- **FOR BEGINNERS, PLEASE OBSERVE THE PARENT-CHILD COMMUNICATION AND LISTEN FOR THE ECHO.**
- **FINDING THE ASHI POINTS REQUIRES STILLNESS AND CENTERING THE MIND ON THE HARIC LEVEL ALWAYS.... NEVER FALL, ALWAYS SINK!!!**



REPEAT SEQUENCE ON OPPOSITE SIDE

**PRONE:
BACKWALKING
ROUTINE**





START BI-LATERAL HOLDING OVER GLUTEAL FOLD. REPOSE IN STILLNESS (ATTUNING TO WATER ELEMENT AND DIRECTING QI TOWARDS THE SPINAL COLUMN)

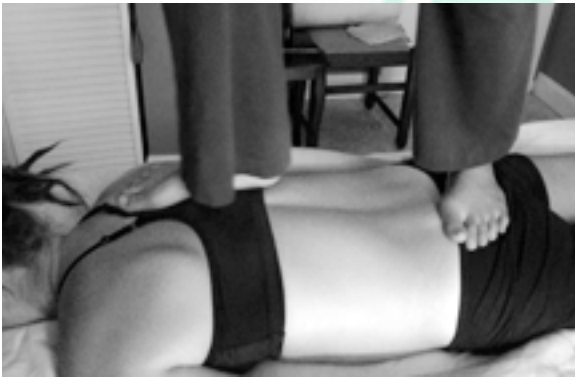

MOTHER FOOT HOLD OVER SACRUM AND CHILD FOOT USING GTP INTO LATERAL BORDER OF T2, 3, 4, 5 NOTE: STUDY SHOULDER PLEXUS OF MERIDIAN NETWORKS. THE FUNCTIONS OF SHOULDER AND ARM EXTREMITIES ARE COORDINATED BY A NETWORK OF MERIDIANS; ACKNOWLEDGING THE SPECIAL RELATIONSHIP BETWEEN THE HEART, LUNG AND PERICARDIUM POINTS. REFER TO ILLUSTRATION: POINTS OF THE SHOULDER AND BACK.



REPOSE IN STILLNESS

SWITCH SIDES

Points of the Shoulder and Back:





BI-FOOTED INVERTED FOOT HOLD OVER SACRUM ACCENTUATING 3 POINTS ALONG THE ILIAC CREST



HOLDING THEN ROCKING (DITS: DURATION, INTENSITY, TIMING, STILLNESS)

REPEAT SEQUENCE UP TO 3 TIMES

Ideas for Practice:

- Adjust body facing the shoulder and feet. LFC, TMP over 8 shoulder points(repeat as needed).
- GTP or TMC over Erector Spinae down towards iliac with Child foot, start from middle jiao points(T9, 10, 11, 12, L1, 2, 3, 4, 5, sacrum points).
- Bi-lateral compressions over upper, middle, upper jiao points (practitioner should listen for the echo along the spinal column in that he or she can detect/intuit where along the spine the *Ashi* points are. *Ashi* points are not recognized as acupoints and are not mapped on the meridian system but are points on the body that release pain. 'A', 'shi' means 'Ah-yes' in Chinese, thus the comment became a name for the description for these points.
- Foot gliding over ES and Shoulder; mother foot over sacrum, child foot gliding accentuating SI 10, 11. Palpate for latissimus dorsi, teres major, insertion points where posterior medial rotators of the humerus converge and lower trapezius into insertion points (upward rotators of the scapula.)



MOTHER FOOT OVER SACRUM ACCENTUATING
E.S. POINTS



BI-FOOTED WALKING FACING FEET OVER E.S.
MUSCLE, SACRUM AND HIP



ACCENTUATION POINT ON SITZ BONES



SINGLE FOOT COMPRESSIONS OVER SHOULDER
LINES 1 & 2

REPEAT ON OPPOSITE SIDE



BI-FOOTED TRAPEZIUS HOLD USING HEEL



SHOULDER WALKING, SINGLE FOOTED

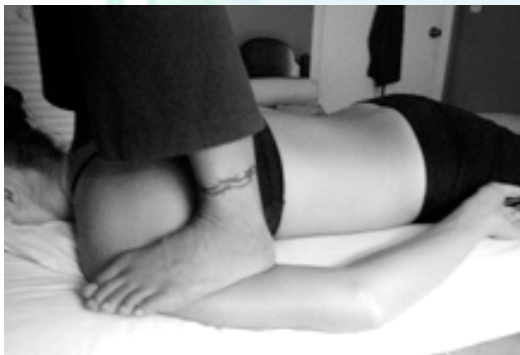

SINGLE FOOT WALK DOWN ARMS



ACCENTUATE REAR DELTOID/TRAP AREA -
ACKNOWLEDGE THE SAN JIAO, PERICARDIUM,
HEART COLLATERALS AND ITS SPECIAL
RELATIONS WITH THE LIVER FUNCTIONS



BI-FOOTED HOLD OVER UPPER AND LOWER ARM



MOTHER FOOT HOLD OVER ELBOW, WALK WITH CHILD FOOT TOWARDS WRISTBONE



ACCENTUATE COMPRESSION OVER WRISTBONE

REPEAT ON OPPOSITE SIDE



STEP UP OVER SACRUM

POWER SEQUENCE: SPINAL ALIGNMENT

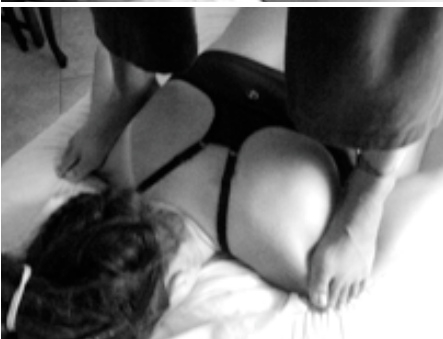

**PRONE:
BENDED KNEE
SEQUENCE**



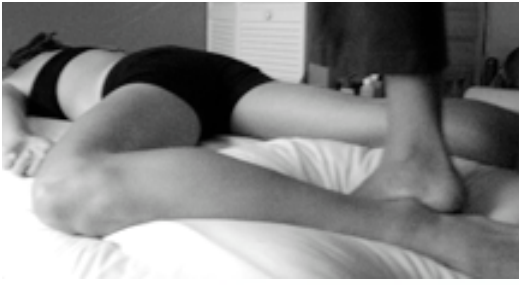

MOTHER FOOT HOLD OVER CALCANEOUS



LFC OVER GALLBLADDER NADI UP THE CALF



COMPRESSING AND HOLDING GB-34



LFC OVER STOMACH NADI



SINGLE-FOOTED WALK UP-DOWN-UP





SFW WITH MOTHER FOOT ON SACRUM



LATERAL STRETCH OF GALLBLADDER NADI
(MOTHER FOOT HOLD OVER GB-34,
COMPRESSING TOP OF THE FOOT DOWN)

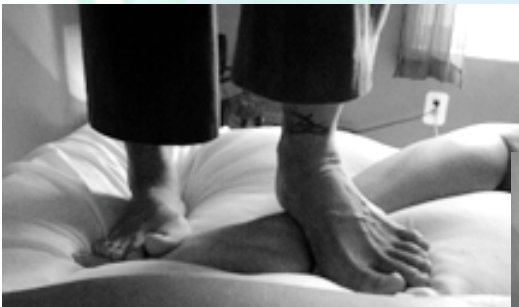

LFC OVER GALLBLADDER NADI TOWARDS THE
KNEE, SINGLE FOOT

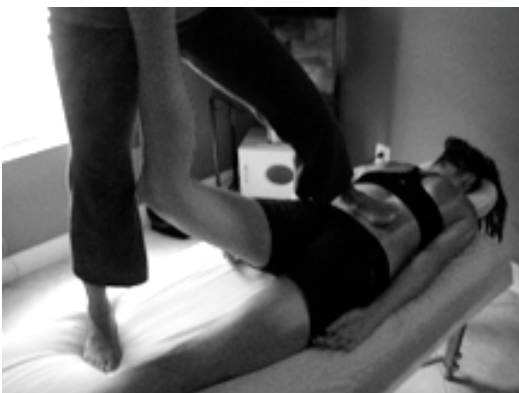
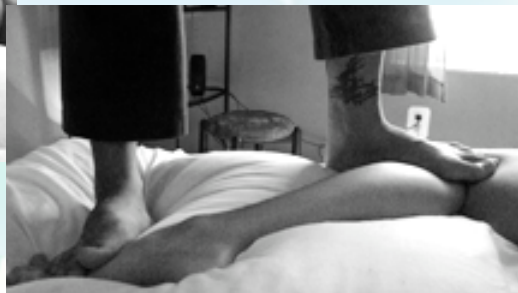

HALF LOCUST 1-2-1

REPEAT ON OPPOSITE SIDE

**PRONE:
WHEELBARROW
SEQUENCE**





ACCENTUATION ON THE SITZ BONE USING HANDS IN DOWN DOG



WALK IN THE PARK (START AND END AT THE GLUTEAL FOLD. ROLLING MEDIAL HAMSTRINGS, ROCKING ON ASHI POINTS.)



VIGOROUS LFC OVER HAMSTRINGS, BEND RECIPIENT'S LEG



ACCENTUATION POINT STANDING ON SACRUM, INVERTED FOOT HOLD (1-2-3-2-1, GTP INTO L4-L5 POINTS)



WHEELBARROW



SUPPORTED WHEELBARROW

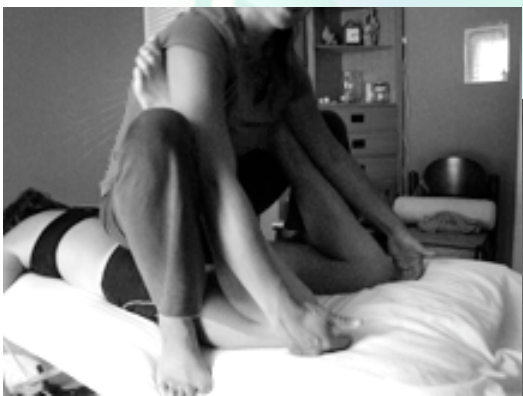

FULL LOCUST



SUPPORTED COBRA



REFERENCE MATERIALS



SAFETY GUIDELINES FOR PRACTITIONER ON BARS

By *Rainbowfire*

I have seen bars of wood, steel and plastic, the best and most sturdy of course being steel. The width should not be so thick that the hands can't fit its circumference. My apologies for not being able to give your carpenter the exact formula however, the following advice should help you when installing ceiling bars.

The height of the table to the bars should be the length of the practitioner's height from the feet to the clavicle. Note: Take into account the receivers' body thickness plus the table height

The ceiling height from the bars to the ceiling should be of ample space so that as the practitioner works his/her head will not scrape or hit the ceiling.

With the practitioner standing on the recipient his or her upper arm while holding the bars should be aligned with the shoulder height meaning the elbow is a bit lower than the armpit
Note: This is important for proper technique application, postural and physical safety.

Always step off the recipient's body from the lower extremities, more specifically from the gluteal fold, as there is sufficient room for handling the body as you dismount off the table

Now that you have installed bars with these precautions in mind you are well on your way to safety. Enjoy the bars! They are precious instruments of amazing functionality.

ARM & SHOULDER POSITIONS FOR BARS

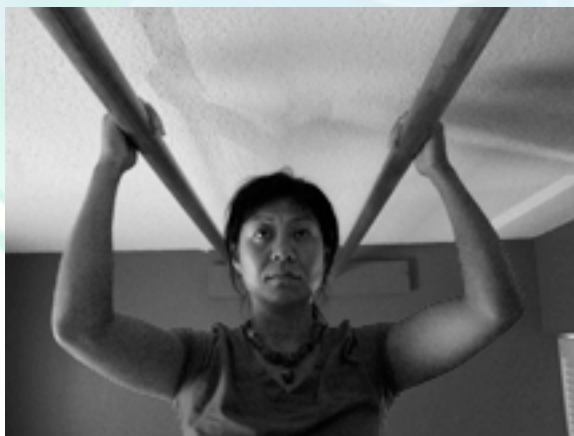

GUA SHA

By *Rainbowfire*



Blood-letting was practiced in the medieval ages up until the 19th century in Europe as was used the idea during Greco-Roman times that certain fluids or humours caused imbalances within the patient's psycho-physiology. Texts in early Aryurvedic medicine also described the healing effects of the letting of blood fluids.

The tribesmen since ancient China used gaomo tools to scrape along the skin's surface to release pain. Today this practice in Chinese medical and folk healing is called Gua Sha.

'Sha' means sand and 'Gua' is to scrape until the raising of Sha. This sha is the congestion of fluids that have become stuck or stagnant. The friction produced by the technique releases this stuck blood thus letting out the sickness or sick qi of the body.

Pathogenic factors both internal and externally related are counteractive to nourishing qi flow. These are cold, dry, wind, heat, damp and damp-heat.

In the example of south Florida living, our environment constitutes a dampness that often cause latency for the spleen and gallbladder vessels. And where there is damp there is excessive heat.

Dredging the collaterals offers freedom from the stagnations of damp but often it is not enough, for a deeper release from chronic, unabated symptoms the practitioner must consider the possibility of sha.

Benefits of Gua Sha are: removal of stuck blood, restorations of ying qi flow, cures stiffness and pain for the associated areas with the stuck qi and blood, normalizes metabolic functions of the soft tissues, muscle and organs, can cool a patient with heat excess, and restore warming for patients with dry and cold symptoms. Because Gua Sha mimics sweating it resolves feverish conditions and calms the brain and kidneys.

Proper technique application requires the knowledge of stroking the cutaneous areas with a degree of accuracy in a flow of movements along a segment of the collateral and in a uni-directional constant.

Eastern anatomy uses various forms for blood-letting or raising sha. It does so without actual blood letting out of the skin rather restores functional harmony of the soft tissue and collaterals at the surface levels. Cups are used as well and striking instruments made of wood-like materials also raise sha. The most famous form of pa-sha or striking instrument is called pa-sha bang, the striking stick.

ACU-MAN: YOUR MERIDIAN DRAWINGS

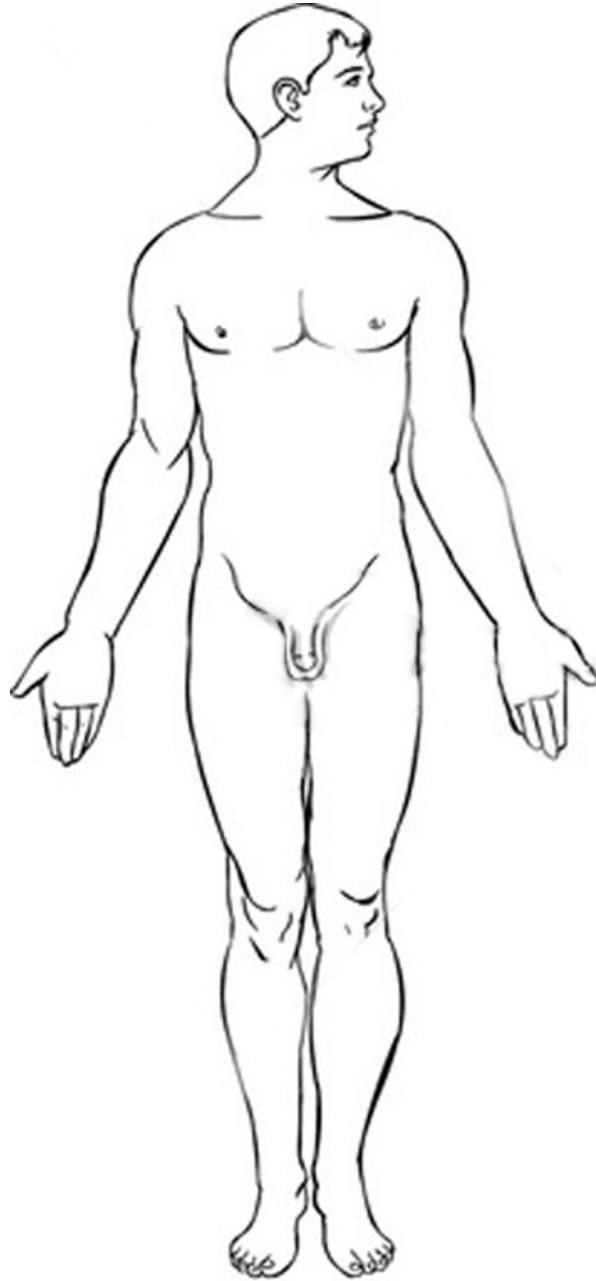

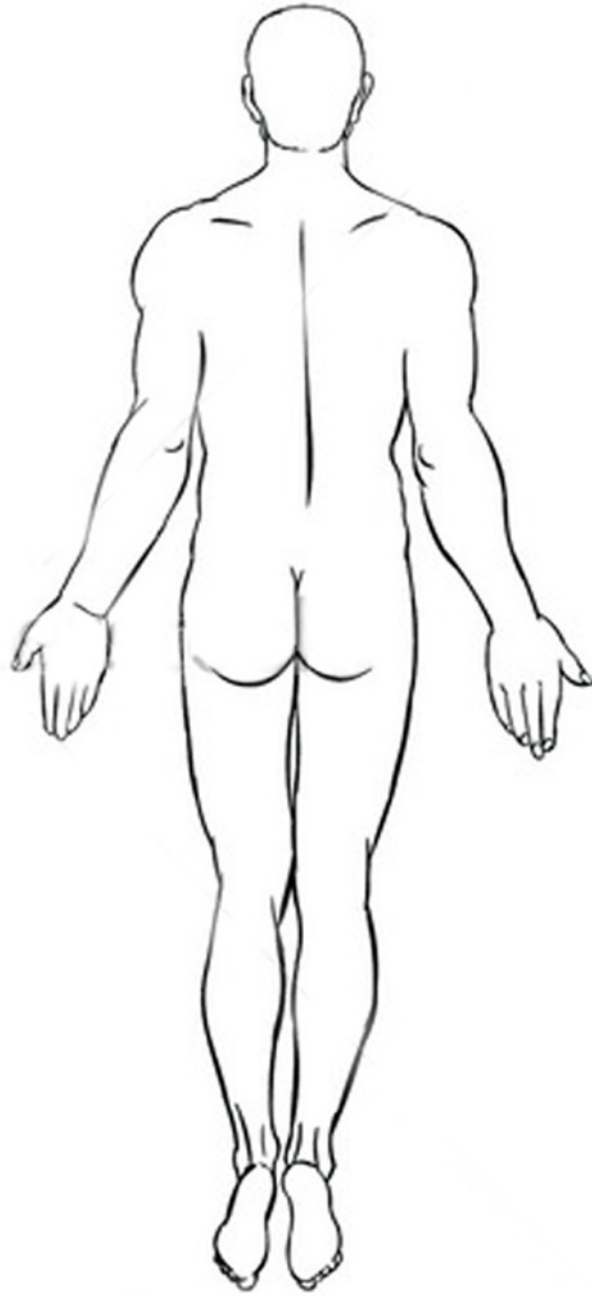



SELF-CARE: THE COSMIC LAWS OF OUR SPIRIT

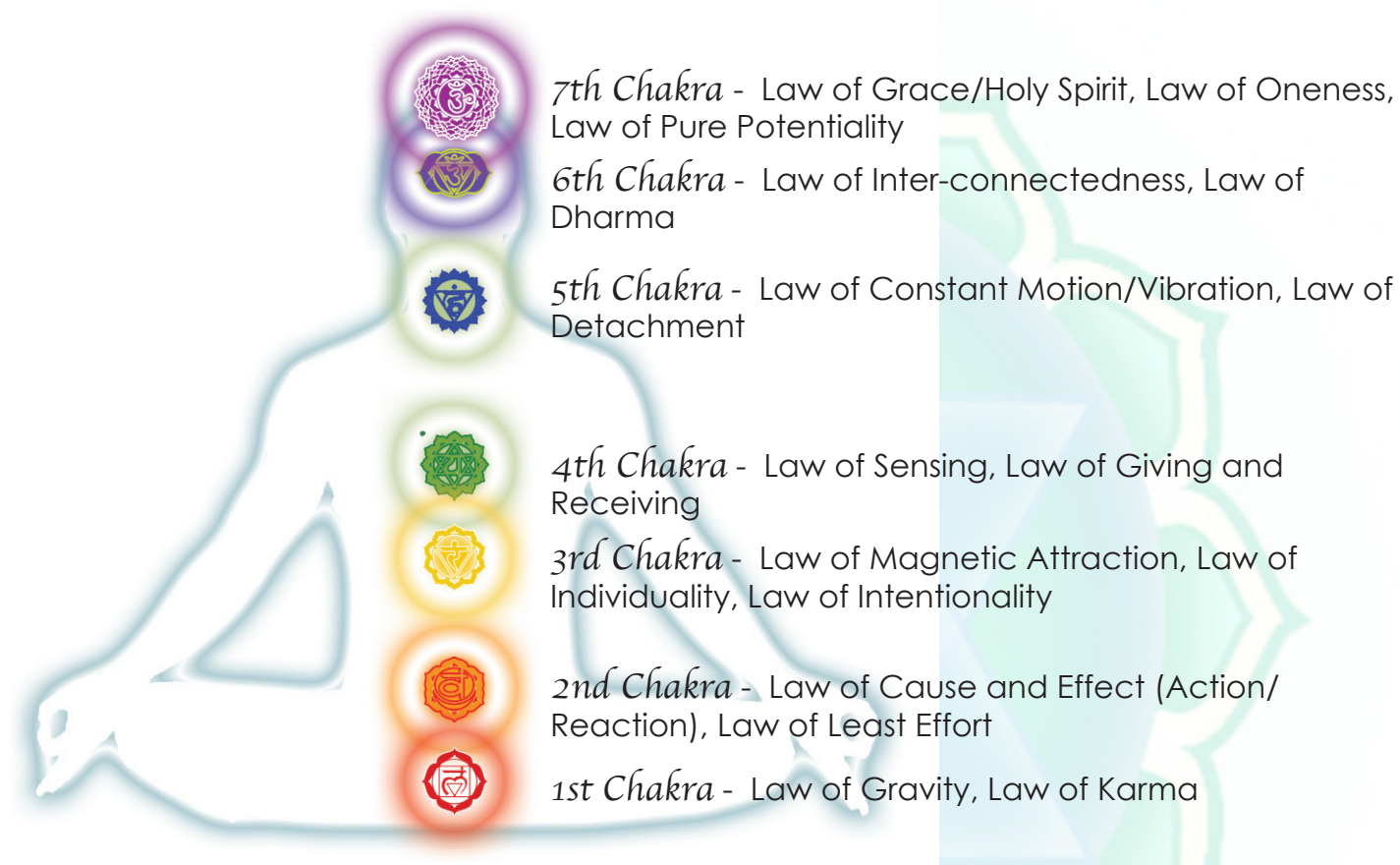

THE GRACES

7TH: GRACE OF WISDOM; GRACE OF HEALING

6TH: GRACE OF KNOWLEDGE/SACRED TRUTH

5TH: GRACE OF COUNCIL; GRACE OF SURRENDER

4TH: GRACE OF FORTITUDE/COURAGE; GRACE OF LOVE

3RD: GRACE OF UNDERSTANDING

2ND: GRACE OF PIETY; GRACE OF PEACE

1ST: GRACE OF REVERENCE

THE EIGHT TRIGRAMS



THE EXTRAORDINARY VESSELS

(奇經八脈; QÍ JĪNG BĀ MÀI)

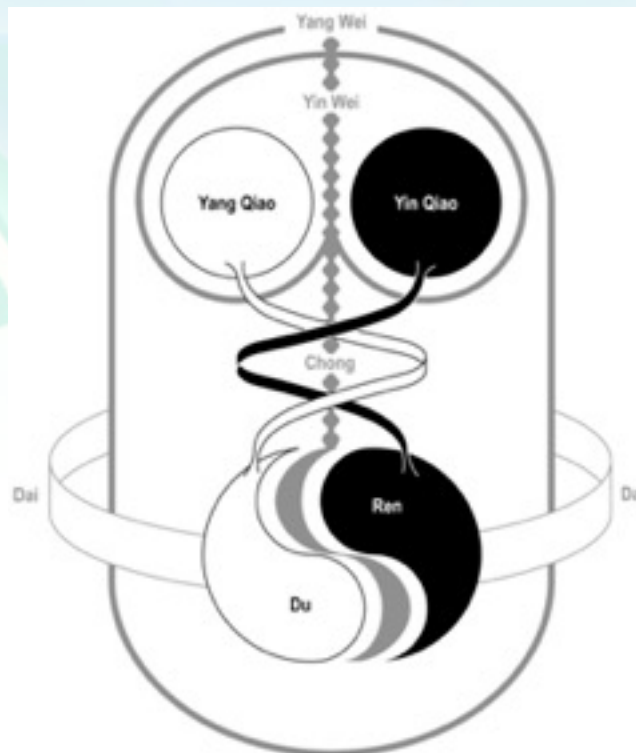

BIG PICTURE

CHART KEY: Abbreviations for Traditional Chinese Energy Lines (Meridians) and Points

ABBREVIATION	LU	LI	ST	SP	HT	SI	UB	KD	PC	SJ	GB	LV	RN	DU
MERIDIAN	Lung	Large Intestine	Stomach	Spleen	Heart	Small Intestine	Urinary Bladder	Kidney	Pericardium	San Jiao	Gall Bladder	Liver	Ren	Du

SPECIAL POINTS	EARTH				HEAVEN				MAN				EXTRA	
	LU	LI	ST	SP	HT	SI	UB	KD	PC	SJ	GB	LV	RN	DU
YUAN-SOURCE	9	4	42	3	7	4	64	3	7	4	40	3		
LUO-CONNECTING	7	6	40	4	5	7	58	4	6	5	37	5	15	1
XI-CLEFT	6	7	34	8	6	6	63	5	4	7	36	6		
FRONT-MU	LU1	ST25	RN12	LV13	RN14	RN4	RN3	GB25	RN17	RN5	GB24	LV14		
BACK-SHU	UB12	UB25	UB21	UB20	UB15	UB27	UB28	UB23	UB14	UB22	UB19	UB18		
ENTRY	1	4	1	1	1	1	1	1	1	1	1	1		
EXIT	7	20	42	21	9	19	67	22	8	22	41	14		

8 INFLUENTIAL POINTS	
ZANG	LV13
FU	RN12
QI	RN17
BLOOD	UB17
SINEWS	GB34
MARROW	GB39
BONES	UB11
VESSELS	LU9

WELL	SPRING	STREAM	RIVER	SEA
Mental illness, chest stifling, fullness under heart	Febrile, complexion change, hot sensations	Bi, wind, damp, heaviness, joint pain	Asthma, cough, hot/cold sensations, voice sound change	Fu organs, stomach, intestines, rebel Qi, diarrhea

GROUP LUO POINTS	
3 ARM YANG	SJ18
3 ARM YIN	PC5
3 LEG YANG	GB35 (GB39)
3 LEG YIN	SP6

WINDOW OF THE SKY	
ST9	SI17
LI18	SJ16
SI16	RN22
UB10	DU16
LU3	PC1

MUSCLE MERIDIAN MEETING POINTS		
3 ARM YANG	Forehead	GB18
3 ARM YIN	Thoracic cavity	GB22
3 LEG YANG	Eyes	SJ18, ST3
3 LEG YIN	Genital	RN3

13 GHOST POINTS												
Palace	Faith	Fortress	Heart	Path	Pillow	Bed	Market	Cave	Hall	Store	Leg	Seal
DU26	LU11	SP1	PC7	UB62	DU16	ST6	RN24	PC8	DU23	RN1	LI11	Haiquan

4 COMMAND POINTS	
ABDOMEN	ST36
HEAD AND BACK OF NECK	LU7
BACK (UPPER & LOWER)	UB40
FACE AND MOUTH	LI4

LOWER HE-SEA POINTS		
3 ARM YANG	LI	ST37
	SI	ST39
	SJ	UB39
3 LEG YANG	ST	ST36
	UB	UB40
	GB	GB34

8 EXTRA MERIDIANS				
	MASTER	XI-CLEFT	LUO	RANGE OF ACTION
REN	LU7		RN15	Abdomen, chest, lungs, throat, face
YIN QIAO	KD6	KD8		
DU	SI3		DU1	Back of legs, back, spine, neck, head, eyes, brain
YANG QIAO	UB62	UB59		
DAI	GB41			Outer aspect of leg, sides of body, shoulders, side of neck
YANG WEI	SJ5	GB35		
CHONG	SP4			Inner aspect of leg, abdomen, chest, heart, stomach
YIN WEI	PC6	KD9		

4 SEA POINTS	
QI	ST9, RN17, DU15, DU14
BLOOD	UB11, ST37, ST39
FOOD	ST30, ST36
MARROW	DU20, DU16

FIVE ELEMENT POINTS ON THE 12 PRIMARY MERIDIANS													
		Well	Spring	Stream	River	Sea			Well	Spring	Stream	River	Sea
		Wood	Fire	Earth	Metal	Water			Metal	Water	Wood	Fire	Earth
TAI	LU	11	10	9	8	5	YANG	LI	1	2	3	5	11
YIN	SP	1	2	3	5	9	MING	ST	45	44	43	41	36
SHAO	HT	9	8	7	4	3	TAI	SI	1	2	3	5	8
YIN	KD	1	2	3	7	10	YANG	UB	67	66	65	60	40
JUE	PC	9	8	7	5	3	SHAO	SJ	1	2	3	6	10
YIN	LV	1	2	3	4	8	YANG	GB	44	43	41	38	34

TERMINOLOGY REFERENCES FOR BAREFOOT MASSAGE



5 Areas of Foot Used in Massage:

- lateral
- medial, accentuating with the big toe
- heel
- bottom foot plantar action
- base of toe plantar action

5 Actions of Massage Using Foot:

- pressing (Talahridaya Marma or TM press, bottom foot press, Great Toe press)
- gliding (lateral, medial sides)
- compressing (single or double foot) - referred to here as LFC (Loving Foot Compressions)
- rocking (single or double foot)
- holding (single or double foot)

5 Actions of the Foot:

- plantar flexion
- dorsiflexion
- inverting
- everting
- rotation

TERMINOLOGY INDEX

ACUPUNCTURE POINTS (腧穴 or 穴位, also called acupoints) are locations on the body that are the focus of acupuncture, acupressure, acupoints and laser acupuncture treatment. Several hundred acupuncture points are considered to be located along meridians (connected points across the anatomy which affect a specific organ or other part of the body). There are also numerous “extra points” not associated with a particular meridian.

ACUPRESSURE is a modality of massage whereby the practitioner palpates and locates the acupoints triggering release of musculotendinatures of the body and facilitating qi flow throughout the energy channels called meridians.

ASHI in Japanese translates as “foot.” Ashi points in Chinese refer to tender points with no fixed location, names or meridians. They often change because the affected areas often change with disease. In Chinese Ah-shi means ‘yes’ referring to the pain sensation detected along the 經絡 jing luò path.

COLLATERALS The collaterals are the transverse branches that bifurcate from the channels. There are fifteen collaterals in all, that is, each of the twelve regular channels has a collateral, plus the Ren and Du channels, and the great collateral of the spleen. The collaterals strengthen the function of the twelve primary meridians and closely connect the exterior-interior related channels. They also assist the transportation and distribution of qi and blood in order to moisten and nourish the whole body.

CUTANEOUS ZONES The twelve cutaneous regions indicate the superficial range of the twelve regular channels on the body surface. As the Suwen describes, “The skin region belongs to the system of regular channels.”

The cutaneous regions are closely associated with the internal organs. Therefore, exogenous pathogenic factors can gradually be transmitted to and invade the internal organs through the cutaneous regions. Conversely, the diseases of the zang-fu organs can be reflected on the cutaneous regions of the body surfaces. This theory of cutaneous regions has a practical value for the application of diagnosis and treatment in traditional Chinese medicine.

DE QI the spontaneous manifestation of qi when the ying Qi or nourishing aspect of Qi arrives to the surface.

EXTRAORDINARY VESSELS Vessels that have no points of their own but are integrated fields governing the most fundamental actions such as protection, digestion, assimilation, incorporation, discharge, storage, distribution and dissolution. Expositions of the Extra 8 vessels by Li Shi Zhen (1518-1593), an eminent figure in Chinese Medical history, emphasize its functional dynamics as an inseparable part of the meridian anatomy and urge practitioners to fully grasp the reality of alchemy by these extra 8 vessels for a complete understanding of pathology, disease and spiritual concepts of our destined purpose. These vessels include chong, ren, du, yin and yang wei, yin and yang qiao and dai.

FIVE-ELEMENT THEORY A functional theory in Chinese Classics describing the dynamics of observable phenomena in creation; they are water/wood/fire/earth/metal. Please see essay.

經絡; JINGLUÒ; JING LUO Jing channels run vertically while Luo channels run laterally. Jing channels are deep to bone level while Luo channels are more superficial.

MERIDIANS 經絡 jingluò is a path through which the life-energy known as “qi” flows, in traditional Chinese medicine. There are about 400 acupuncture points and 20 meridians connecting most of the points, however by the 2nd Century CE, 649 acupuncture points were recognized in China. These 20 meridians include the “twelve regular channels” or “twelve regular meridians”, with each meridian corresponding to each organ; nourishing it and extending to an extremity. There are also “Eight Extraordinary Channels” or meridians, two of which have their own sets of points, and the remaining ones connecting points on other channels.

QI In traditional Chinese culture, qì (also chi or ch’i) is an active principle forming part of any living thing. Qi is frequently translated as life energy, life-force, or energy flow. Qi is the central underlying principle in traditional Chinese medicine and martial arts. The literal translation of “qi” is breath, air, or gas.

SHEN Chinese Classics consider the three treasures of life-force as qi-shen-jing. Shen is a yang aspect of life-force indicative of spiritual fire. The vibrancy in ones eyes that is a manifestation of ones contact with holistic health and integrity of living grace.

UPPER, MIDDLE, LOWER JIAO The movement of the path of Qi as it travels and disperses can be subdivided into upper, middle and lower jiao. Upper governs the head, neck, upper chest, arms, heart and lung (C1-T5), Middle governs stomach, spleen/pancreas, liver, gall bladder and the trunk (T5-L1). Lower governs kidney, bladder, reproductive regions and systems and lower extremities.

WEI QI the defenses of the cutaneous zones forms the superficial immune responses of the body.

YIN/YANG The two sides of the inseparable one. The origin of the universe is also the key into itself within the yin/yang dualism. Its correspondences vary as widely as the scope of the cosmos from relative to non-relative terms. Everything we know has a beginning and end. Everything we are is a manifestation of the original one.

YING QI We can define ying qi as “nutrient qi”. Nutrient qi is the essence of water and grain: When it is harmoniously balanced in the five zang and dispersed through the six fu, it can enter the vessels. It is an aspect of blood that travels through the primary vessels providing nourishment.

YING WEI The Chinese Medicine’s term for the system of maintaining one’s health and prevention of illness and practices of longevity i.e. qigong, acupuncture, dao yin, meditation, xiu lian, tai chi, herbs, feng shui, Tui Na, An Mo, five-element nutrition, proper sleeping and eating cycles.

ZANG-FU is a collective term for internal organs that are divided into two major categories, namely the five zang-organs and the six fu-organs. The five zang-organs include the heart, the liver, the spleen, the lung and the kidney; the six fu-organs include the gallbladder, the stomach, the small intestine, the large intestine, the urinary bladder and sanjiao. Another group categorized as the extraordinary fu-organs include the brain, the marrow, the bones, the vessels, the gallbladder and the uterus.

CHART KEY: Abbreviations for Traditional Chinese Energy Lines (Meridians) and Points

ABBREVIATION	LU	LI	ST	SP	HT	SI	UB	KD	PC	SJ	GB	LV	RN	DU
MERIDIAN	Lung	Large Intestine	Stomach	Spleen	Heart	Small Intestine	Urinary Bladder	Kidney	Pericardium	San Jiao	Gall Bladder	Liver	Ren	Du